

# Sentence Processing

## 4

*Time flies like an arrow. Fruit flies like a banana.*

MARX

When people speak, they produce sequences of words. When people listen or read, they also deal with sequences of words. Speakers systematically organize those sequences of words into phrases, clauses, and sentences. When listeners try to comprehend those sequences, they have to determine how the sequence of words is organized, and use this information to recover the speaker's intended meaning. Language scientists investigate how people organize words before and during speaking and how listeners and readers use cues to figure out how words in sentences relate to one another. The cues that speakers and writers produce in sentences are vital in enabling listeners to recover the intended message. The study of *syntax* involves discovering the cues that languages provide that show how words in sentences relate to one another. The study of *syntactic parsing* involves discovering how comprehenders use those cues to determine how words in sentences relate to one another during the process of interpreting a sentence.

Here's an example of how the organization of words into phrases can affect meaning (see Pinker, 1994; see also Bever, 1970; Columbia Press, 1980):

(1) Dr. Phil discussed sex with Rush Limbaugh.

*Introduction to Psycholinguistics: Understanding Language Science*, Second Edition.  
Matthew J. Traxler.

© 2023 John Wiley & Sons Ltd. Published 2023 by John Wiley & Sons Ltd.  
Companion Website: [www.wiley.com/go/traxler/psycholinguistics2e](http://www.wiley.com/go/traxler/psycholinguistics2e)

Models of Parsing: Two-stage Models

Models of Parsing: Constraint-based Models

*Story context effects*

*Subcategory frequency effects*

*Cross-linguistic frequency data*

*Semantic effects*

*Prosody*

*Visual context effects*

Interim Summary

Argument Structure Hypothesis

Limitations, Criticisms, and Some Alternative Parsing Theories

*Construal*

*Good-enough parsing*

Parsing Long-distance Dependencies

Summary and Conclusions

Test Yourself

Listeners (and readers) could mentally organize the words in this sentence in at least two distinct ways, and the way the sentence is organized determines what it means. The likely intended meaning happens when readers treat the *prepositional phrase* “with Rush Limbaugh” as being closely related to the verb *discussed*. This meaning would fall out of the following hypothetical conversation (Conversation 1):

You: Who did Dr. Phil have on his radio show this morning?

Me: He had Rush Limbaugh on the show.

You: What did they talk about?

Me: They talked about sex. Dr. Phil discussed sex with Rush Limbaugh.

In this conversation, the critical thing that the listener needs to do is to package *discussed* and *sex* together, as in *Dr. Phil (discussed sex)* and the listener needs to tie that whole thing to *with Rush Limbaugh*. We could paraphrase that meaning as, “Dr. Phil had a discussion with Rush Limbaugh; the discussion was about sex.”

The other way to organize the sentence involves treating the *prepositional phrase* *with Rush Limbaugh* as being closely related to the noun *sex*. This other meaning would emerge from a conversation like this one (Conversation 2):

You: Who did Dr. Phil have sex with?

Me: Dr. Phil had sex with Rush Limbaugh.

You: I don't believe you.

Me: Really. He talked about it afterwards. Dr. Phil discussed sex with Rush Limbaugh.

You: !

If we wanted to draw a diagram that depicts the different ways that we could organize the words in *Dr. Phil discussed sex with Rush Limbaugh*, we could use a *phrase structure tree* (or *tree diagram*). Phrase structure trees can seem complicated, but they are really just a handy way of showing how words in sentences relate to one another.<sup>1</sup>

Every sentence has to have a noun phrase (NP) and a verb phrase (VP). So the top of our phrase structure tree will have an “S” (for *sentence*), and below that, we will have an “NP” (for *noun phrase*) and a “VP” (for *verb phrase*), like this:

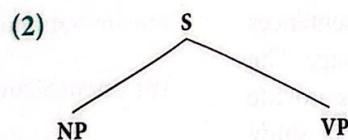

This part of the diagram shows that we have a sentence, and that the sentence consists of one NP and one VP. In a phrase structure tree, the labels, like NP, VP, and S, are called *nodes* and the connections between the different nodes form *branches*. The patterns of nodes and branches show how the words in the sentence are grouped together to form phrases and clauses.

In sentence (1), the leftmost NP will consist of *Dr. Phil* no matter what meaning is assigned, so let's go ahead and add that to our tree below the NP node.

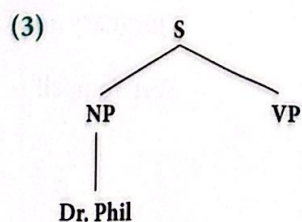

The important differences in the structure of sentence (1) all occur inside the VP node. The meaning that Conversation 1 expresses involves *with Rush Limbaugh* modifying the meaning of *discussed sex*. To express that relationship, we need to organize our VP node so that *with Rush Limbaugh* is assigned as a modifier of the verb *discussed*. We can do that by organizing the VP like this:

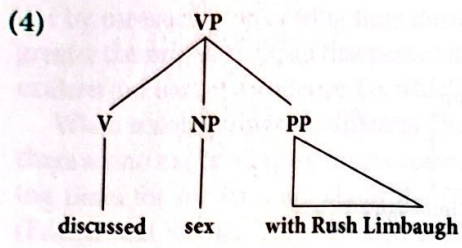

(The "PP" stands for *prepositional phrase*. Words like *with*, *of*, *in*, and so forth are called prepositions.)

If we want to get the meaning in Conversation 2, we need to organize the VP differently. We have to put *with Rush Limbaugh* and *sex* together. We can do that using a structure like this one:

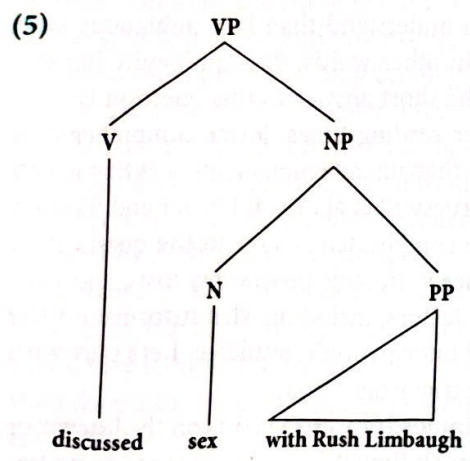

Now that we have our VP diagrams sorted out, we can build two different trees, one that captures the meaning in Conversation 1 (6a) and one that captures the meaning in Conversation 2 (6b):

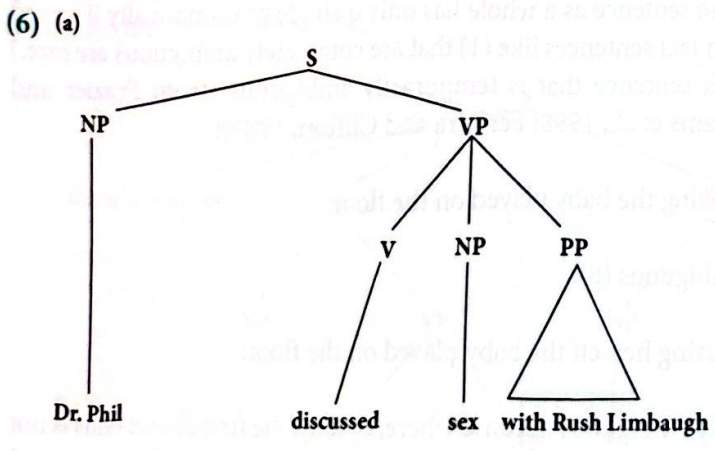

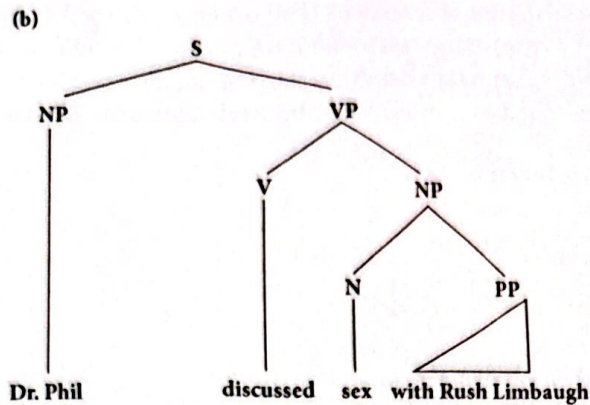

Although there is more to sentence processing than just figuring out which words go together to make phrases, language scientists have learned a great deal about the mental processes that people use to interpret sentences by studying *globally ambiguous* sentences like (1). Globally ambiguous sentences have sequences of words that can be organized in more than one way, and those different ways of organizing the sentence are all consistent with the grammar of the language.

Are ambiguous sentences like (1) harder to understand than less ambiguous sentences that express about the same meaning? In other words, does ambiguity impose processing costs on the listener (or reader)? The short answer to this question is: Yes, sometimes ambiguous sentences lead to longer reading times, lower comprehension accuracy, and different patterns of brain activity than unambiguous sentences that mean the same thing (see Brothers et al., 2021; J. C. Trueswell et al., 1994; Frazier and Rayner, 1982; Kutas et al., 2006). The longer and more complicated answer to the question is: There are cases where ambiguity doesn't produce noticeable processing costs, and ultimately processing costs depend on a variety of factors, including what information the listener has just processed and what contextual information is available. Let's start with the straightforward cases and come back to the tricky ones later.

How do we know that ambiguous sentences impose processing costs on the listener or reader? One thing we can do is measure how much time it takes for someone to understand a sentence that is ambiguous, and compare that to how much time it takes for someone to understand a sentence that is unambiguous. Most of the time when language scientists do this they are investigating sentences that are only *temporarily ambiguous*. Temporarily ambiguous sentences contain a sequence of words that can be configured in more than one way, but the sentence as a whole has only a single grammatically licensed or acceptable structure. (In fact sentences like (1) that are completely ambiguous are rare.)

Here's an example of a sentence that is temporarily ambiguous (from Frazier and Rayner, 1982; see also Adams et al., 1998; Ferreira and Clifton, 1986):

(7) While Susan was dressing the baby played on the floor.

Compare (7) to the unambiguous (8):

(8) While Susan was dressing herself the baby played on the floor.

Sentence (7) is temporarily ambiguous because where, exactly, the first clause ends is not entirely clear. It could end after *the baby*, but it really ends after *dressing*. Listeners (and readers) need to figure out whether the NP *the baby* is supposed to go with the preceding *Susan was dressing*, as in *Susan was dressing the baby*, or whether *the baby* starts a new clause, as in *Susan was dressing (herself) and the baby played on the floor*. In (8), the

sentence is unambiguous because *herself* closes off the *subordinate clause* “*While Susan was dressing herself*” and there is no way to put *the baby* in that clause.

In sentence (7), listeners have to figure out whether the *baby* goes with *Susan was dressing* or starts up a new clause. Do they come up with the correct solution right away? Or do they make mistakes? Alternatively, in cases of uncertainty, do they delay making any decision until they have enough information to be certain that they are correct? We can find out by measuring processing time during critical parts of the sentence. In general, the greater the processing load that part of the sentence imposes, the longer it takes people to understand part of a sentence. So, which parts of sentence (7) are difficult to process?

When reading times for different parts of sentence (7) are measured, they show that there are no major increases in processing load during the ambiguous part. That is, reading times for *the baby* are about the same whether the sentence is ambiguous or not (Frazier and Rayner, 1982; Traxler, 2002, 2005). Readers get through *While Susan was dressing the baby* just as fast as the equivalent parts of the unambiguous sentence (8). So ambiguity, in and of itself, is not a huge burden on the listener or the reader. Where people *do* slow down is at the verb *played*. People have much more trouble processing *played* in sentence (7) than they do in sentence (8). Why is that? And what does it mean?

It means a couple of things. First, it means that listeners and readers are making decisions about how to organize words into phrases and clauses before they have enough information to be certain of making the correct decision. This means that, in sentence processing, just as in word processing, listeners and readers follow the *immediacy principle* and use an *incremental processing strategy* as they encounter each word (Foss and Hakes, 1982; Just and Carpenter, 1980). The immediacy principle says that people do as much interpretive work as they can based on partial information and making possibly incorrect assumptions, rather than waiting until they have all the information they need to be certain of making the correct decision. Second, it means that making structural choices, by itself, is not very difficult to do. If it were, people should slow down at points of sentences where more structural choices were available to them, and this does not seem to be the case. Finally, it means that when people have a choice of different structures, they sometimes make the wrong choice. If they always made the correct choice, then there should be no problem processing any part of sentence (7). The fact that readers slow down at the verb *played* suggests that something special is happening at that point of the sentence. What might that be?

One explanation is that, during the beginning of the sentence (*While Susan was dressing the baby*), listeners and readers treat *the baby* as the thing that is being dressed, they include *the baby* in the same clause as *Susan was dressing*, and this leads to processing problems shortly thereafter. To interpret the sentence that way, listeners need to build a structure like that shown in (9):

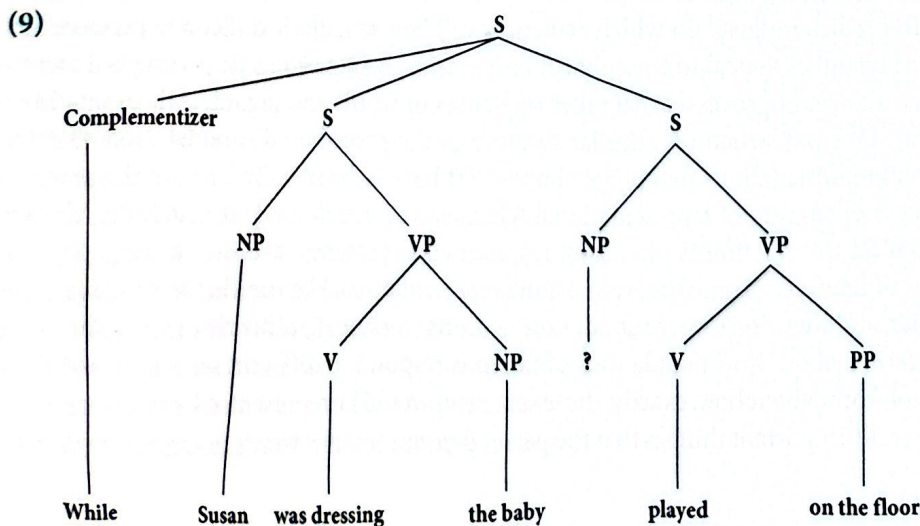

If the beginning of the sentence is packaged as shown in (9), then the verb *played* has no subject (the verb *was dressing* has, metaphorically, stolen *the baby* away from its rightful owner). If *the baby* is assigned or attached to the verb *was dressing*, there is no grammatically acceptable or legal way for the listener to incorporate the verb *played* into a single sentence with *While Susan was dressing the baby ...* The solution to this dilemma is for the comprehenders to undo their original structural commitments—in other words, to take *the baby* away from *was dressing* and give it back to its rightful owner *played*. To do that, comprehenders must adopt or build a syntactic structure like that shown in (10):

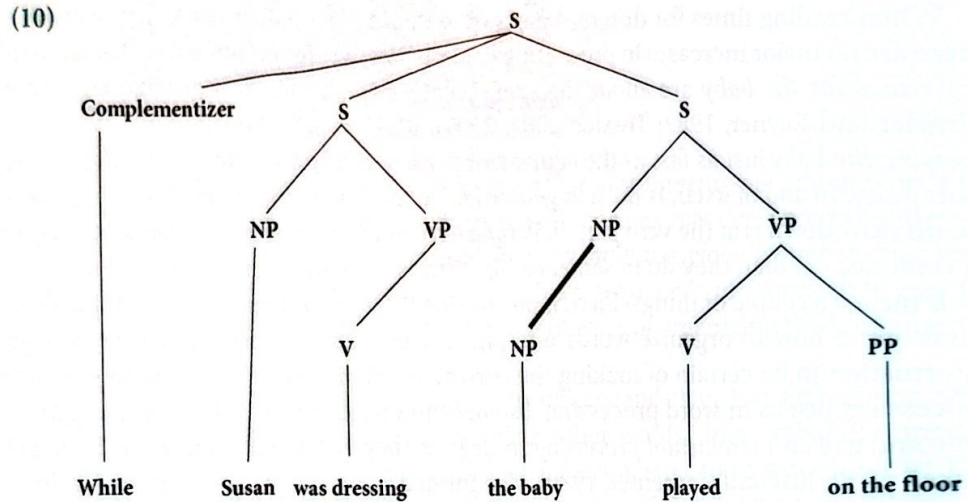

This correct structural configuration then leads to the correct meaning being assigned, Susan dressed (herself) and the baby played on the floor. Notice that baby-stealing is not possible in sentence (8), and so there is no need to do the mental work of disconnecting *dressing* and *the baby*, no need to unmake structural decisions, and no need to revise an incorrect structure. (*herself* fills the object role in (8) that *the baby* tries to fill in (7)).

Language scientists have investigated a wide variety of *garden path* sentences, and they have consistently found that sentences like (7), where listeners initially build one syntactic structure (e.g. (9)) and later replace that structure with another (e.g. (10)), are harder to understand (take longer and lead to more errors of interpretation) than equivalent sentences that are unambiguous (Britt, 1994; Ferreira and Clifton, 1986; Frazier and Rayner, 1982; Fujita, 2021; Konieczny and Hemforth, 2000; Phillips et al., 2005; Pickering and Traxler, 1998; Rayner et al., 1983; Altmann and Steedman, 1988; Trueswell et al., 1993). They have therefore spent a lot of time developing theories that explain how, exactly, people react to garden path sentences and what, exactly, makes them difficult to process.

To predict and explain which sentences will be particularly difficult to process, language scientists appeal to the concept of *syntactic parsing*. Syntactic parsing is a mental process or set of processes that takes sequences of words and organizes them into hierarchical mental structures (similar to those in the preceding diagrams). Note that the mental representations that people build don't have to be literally "trees in the head." A number of equivalent representational schemes are possible, and ultimately the relevant structural information is physically represented as patterns of firings in large populations of neurons. (Some theories assume representations like the phrase structure trees earlier, and they don't worry about how neurons work at all; other theories are far more concerned about how populations of neurons respond to different sentences, and they do not worry about how, exactly, those sentences would be represented by tree diagrams.) The really important thing is that the parser determines how words in sentences relate to

one another. The *syntactic structures*, and our diagrams, are just a way of keeping track of these relationships. A *syntactic parser*, or simply *parser*, is a mechanism that carries out processes that identify relationships between words in sentences. Many different sets of processes could accomplish the task of organizing sequences of words into hierarchical structures. Language scientists would like to find out which specific set of processes people actually use when they parse sentences. The next section of this chapter will explore some of these accounts, starting with Lyn Frazier's classic *garden path* theory.

## Models of Parsing: Two-stage Models

Sentences like (7) metaphorically lead you down the garden path and leave you stranded there so that you have to make your way back and choose a different path. So they are often called garden path sentences. The idea that listeners build the wrong structure for some temporarily ambiguous sentences (such as sentence (7)) while they are processing the ambiguous part, discover their error when they get to the *disambiguating* information (e.g. *played* in (7)), and then revise their initial syntactic (structural) and semantic (meaning) commitments sits at the core of the garden path approach to sentence processing and interpretation (Frazier, 1979, 1987). Frazier's garden path theory is considered a *two-stage* model of syntactic parsing because she proposes that syntactic parsing takes place in two distinct processing stages or steps. In the first stage, the incoming sequence of words is analyzed to determine what *categories* the words belong to (categories correspond to parts of speech, such as noun, verb, preposition, and so on). Once the categories have been identified, the parser can build a syntactic structure for the sequence. Note that *no* other information besides word category information is used in the initial structure-building process. The parser does not care which particular words it is looking at—it only wants to know what categories are represented in the input. In the second stage of sentence interpretation, standard meaning is computed by applying semantic rules to the structured input. Next, let's look at the two proposed stages of processing in a bit more detail.

In the first stage, a lexical processor identifies the categories that are represented in the input, and its output is fed into the syntactic parsing mechanism (see Figure 4.1). If we feed the sentence *While Susan was dressing the baby played on the floor* into the lexical processor, it will output this sequence of categories:

conjunction–noun–verb–determiner–noun–verb–preposition–determiner–noun

The parser can build a syntactic structure for this string of categories without knowing what specific words are actually represented in the input. Once a syntactic structure has been built, the actual words in the sentence can be assigned positions in the tree (as in (10)), and the entire configuration can be sent to a *thematic interpreter*. The thematic interpreter's job is to apply a set of rules that assigns roles to each of the elements in the syntactic tree, based on their position in the tree and how they are connected to other words. For example, grammatical subjects are treated as being old or given information, and the system prefers to treat them as the initiator of the action described in the clause. If the thematic interpreter produces a meaning that makes sense, is consistent with the listener's prior knowledge or assumptions, and can be readily integrated with preceding sentences in the discourse, then the process of interpreting the sentence ends and the listener can move on to the next one. If the thematic interpreter produces a meaning that lacks one or more of these qualities, one remedy is to send a signal to the syntactic parser

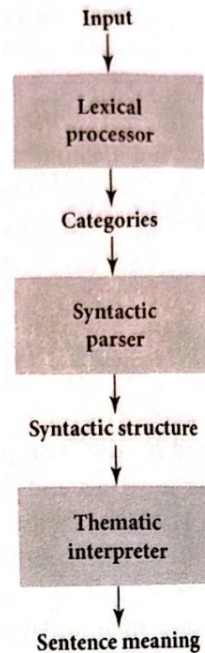

**Figure 4.1** The garden path model of syntactic parsing

that prompts the parser to try to find an alternative structure for the sequence of words (and note that for the parser, unlike NASA, failure is always an option).

Garden path theory assumes that the parser begins to build a syntactic structure as soon as the lexical processor begins to deliver information about word categories. The thematic processor also appears to work on a word-by-word basis (Brothers, 2022). That is, semantic interpretation does not wait until the end of a phrase or a clause—listeners monitor the meaning of utterances constantly as they are processing those utterances, and the process of interpretation will slow down or stop as soon as listeners detect either syntactic or semantic problems with the input.

According to garden path theory, it is this rush to interpretation that sometimes leads people astray. Because structural and semantic decisions are made on a word-by-word basis, the parser is forced to choose between alternative structures when more than one structure is compatible with the input (rather than delaying a decision to collect more evidence). So the parser often chooses which structural option to pursue before it has definitive information about which structure is actually required. The parser often makes the correct decision, but, as we saw in example sentence (7), sometimes it does not. When the parser makes an incorrect decision, the structure that it built initially has to be undone, and processing is disrupted.

Two important consequences follow from these assumptions: First, for garden path theory to work as a general theory of parsing, it needs to explain how people make choices when more than one syntactic structure is possible. Second, for garden path theory to work as a theory about how *people* parse sentences, there should be evidence that people have problems at just those points in sentences where garden path theory says structural reanalysis is taking place. (It is also possible that garden path theory could claim that the act of making a structural choice imposed processing costs, but as we noted before, there is little or no evidence that making structural decisions, by itself, leads to any significant processing difficulty.)

So, according to garden path theory, how do people decide which structure to build when more than one structure is grammatically acceptable (or *licensed*) and consistent

with the sequence of categories at a particular point in the sentence? First, garden path theory assumes that people can only build one syntactic structure at a time. That means that it represents a kind of *serial* processing system (as opposed to a *parallel* processing system, which could build more than one structure at a time). Second, garden path theory says that the overarching principle that the parser relies on is *simplicity*. That is, the parser seeks to build the least complicated structure that it can. Pursuing the simpler structure conveys two main benefits. First, simpler structures take less time to build than more complicated structures. Second, simpler structures place lower demands on cognitive resources like working memory than more complicated structures do, and reduced demands on working memory also translates into greater speed.

According to garden path theory, the parser pursues its structure-building goals and obeys the simplicity principle by deploying processing *heuristics*, basic rules that can be applied quickly and consistently, to make decisions about which structure to build at any given point. Heuristics have some advantages and some drawbacks. The main advantage is that decisions can be made very quickly on the basis of incomplete information—and people need to make sentence processing decisions quickly because language input arrives at a rate of about 200 words per minute in both speech and reading. The main disadvantage is that heuristics can lead to incorrect decisions (syntactic structure-building errors). However, the occasional error that heuristics lead to, and the resulting delay in getting to the correct interpretation, is outweighed by the overall time savings that heuristics provide.

The classic version of garden path theory proposes two heuristics: *late closure* and *minimal attachment*. Late closure says *Do not postulate unnecessary structure. If possible, continue to work on the same phrase or clause as long as possible*. Minimal attachment says *When more than one structure is licensed and consistent with the input, build the structure with the fewest nodes*. More recent variants of the garden path approach postulate additional principles, such as the *main assertion preference*, which says *Given a choice between two structures, build the structure where the new elements relate to the main assertion of the sentence*. Let's look at how these three rules operate, starting with the late closure heuristic.

In sentence (7), when listeners get to the NP *the baby*, they can choose to attach it as part of the preceding clause, as in: [While Susan was dressing the baby ...]. Alternatively, they can choose to close off the first clause right after *dressing*. In that case, the phrasal organization would look like this: [While Susan was dressing] [the baby ...]. The late closure heuristic dictates that the first organization will be pursued, because doing so allows the parser to continue working on the same clause. Pursuing the second organization means that the parser has to start building a new clause before there is definitive evidence that the first clause really is finished. The actual structure of sentence (7) is incompatible with this initial choice, however, and so additional processing is needed to revise the structure. Sentence (8) is compatible with the parser's initial choice (the parser chooses to put *herself* in the first clause, which is correct), so no additional processing takes place. Hence, garden path theory predicts that sentence (7) should be harder to process than sentence (8), and that prediction has been confirmed in numerous experiments where people's reading times were measured (e.g. Brothers et al., 2021; Frazier and Rayner, 1982; Traxler, 2002, 2005). People consistently slow down in sentence (7) when they get to the main verb *played*, which is the point where the parser's initial structural assumptions are shown to be false.

To look at how minimal attachment works, let's look at a sentence that is similar to sentence (1), but where semantic (meaning) information forces an interpretation like that diagrammed in (6b).

(11) The burglar blew up the safe with the rusty lock.

Here, semantic information forces people to adopt a structure like (6b) because safes can have rusty locks, but you can't use a rusty lock to blow up a safe. In a sentence like (12), people adopt a structure like (6a) because you can use dynamite to blow up a safe.

(12) The burglar blew up the safe with the dynamite.

Look at (6), and count the number of nodes that it takes to represent the intended meaning of sentence (11). Notice that (6a) has fewer nodes than (6b). Because minimal attachment says "build the tree with the fewest nodes," when people listen to sentence (11), they will build the structure where *rusty lock* is attached to *blew up* (rather than *safe*). According to garden path theory, when the structure in (6a) is sent to the thematic processor with the words in sentence (11), the thematic processor will generate an error message (because it does not make sense to use a rusty lock to blow up a safe). In sentence (12), the minimal attachment heuristic leads to the correct syntactic structure, and the thematic processor has no trouble because the parser's output places *dynamite* and *blew up* together, and it makes sense to use dynamite to blow something up. (Notice that the minimal attachment heuristic also leads to the preferred and non-slandering interpretation of *Dr. Phil discussed sex with Rush Limbaugh*.)

When researchers measured how long it took people to understand sentences like (11) and (12), they found that people took longer to understand sentences like (11) (Rayner et al., 1983). Why is this? One possibility is that people really use the minimal attachment heuristic to make structural decisions. Because the structure that listeners have to build for sentence (11) is more complicated than the structure that they have to build for sentence (12), they initially adopt the simpler structure, and this leads to problems when the thematic interpreter really needs the more complicated structure (as it does when it processes sentence (11)). Thus, garden path theory has provided two sets of predictions that were confirmed by observing people's behavior as they processed sentences.

Sometimes different sentence-processing heuristics pull listeners in different directions at the same time. For example, the *main assertion* heuristic operates in cases like (13) and (14):

(13) The young woman delivered the bread that she baked to the store today.

(14) The young woman baked the bread that she delivered to the store today.

The main assertion heuristic says, "When you have a choice of where to attach new information, attach it so that it goes with the sentence's main assertion." When listeners get to the prepositional phrase *to the store* in (13) and (14), they have to choose whether to attach that phrase to the main verb in the sentence (*delivered* in (13), *baked* in (14)) or to the more recently encountered verb (*baked* in (13), *delivered* in (14)). The second verb is inside a *relative clause*, which in turn is modifying (providing additional information about) the preceding noun *bread*. The main assertion of the sentence is provided by the main clause (*The young woman delivered the bread*), rather than the relative clause which provides additional, elaborative information. As a result, the main assertion heuristic predicts that people will have less trouble with sentence (13) than sentence (14) (Can you work out why this should be so?) However, the late closure heuristic makes the opposite prediction. It says that, when listeners get to the prepositional phrase *to the store*, they are currently working on the relative clause (*bread that she baked/bread that she delivered*). As a result, late closure says that (14) should be easier than (13). (Agree or disagree? Can you see if you can work out why this is so.) In cases like this, garden path theory predicts that people will have no more trouble processing sentences like (13) than sentences like (14) because, while the main assertion heuristic motivates attaching the prepositional phrase

to the first verb, this preference is canceled out by the late closure heuristic. That prediction has been confirmed by measuring people's reading times—reading times are equivalent for sentences like (13) and (14) (Traxler and Frazier, 2008).

What happens when the main assertion preference is deactivated? That happens when the prepositional phrase *to the store* appears in a *subordinate clause*, as it does in sentences (15) and (16):

- (15) Before the young woman delivered the bread that she baked to the store today, the clerk stacked the shelves.
- (16) Before the young woman baked the bread that she delivered to the store today, the clerk stacked the shelves.

In (15) and (16), the main assertion is *the clerk stacked the shelves*, and there is no grammatically licensed way to associate the prepositional phrase *to the store* with the main assertion. When the main assertion preference is deactivated in this way, garden path theory says that the late closure heuristic should dominate people's structural choices. As a result, the prepositional phrase *to the store* should be easier to process in sentences like (16) than sentences like (15), and this is the pattern that appears in people's reading times (Traxler and Frazier, 2008).

Findings like these suggest that the parser deploys heuristics in a flexible way. The specific heuristics that are used at any given point in time depend on the characteristics of the sentences that are being processed. So, to predict how people will react to any given sentence, we need to know what properties the sentence has (what kinds of phrases and clauses it contains) and we need to know what processing heuristics people will use for that kind of sentence. One of the advantages of garden path theory is that it makes fairly specific claims about both of these things, so it is testable and potentially falsifiable.

## Models of Parsing: Constraint-based Models

Now that we have surveyed the garden path model, it is time to explore some alternative theories. *Constraint-based* parsing models constitute the most prominent alternative to two-stage models (e.g. MacDonald et al., 1994; Seidenberg and MacDonald, 2018; Tanenhaus et al., 1995; Trueswell et al., 1993). There are two critical differences between the garden path and constraint-based models. The first is that, rather than building one structure at a time, constraint-based parsers can pursue multiple structural possibilities simultaneously. Constraint-based parsers oftentimes adopt a parallel distributed processing/neural network architecture, similar to the one used by the TRACE model of lexical processing (e.g. Elman, 1994, 2004; Rohde and Plaut, 1999; Spivey-Knowlton and Sedivy, 1995; St. John and McClelland, 1992; Stevenson, 1994; Tabor and Hutchins, 2004). Constraint-based parsers represent different aspects of sentences, including their syntactic structures, as patterns of activation spread across large numbers of interconnected processing units. These groups of processing units and the connections among them are intended to resemble the functioning of networks of neurons in the brain. As in the TRACE model, partial and incomplete information can lead to partial activation of multiple mental representations, so at any given point in a sentence, the neural network could have multiple syntactic structure representations partially activated. The system as a whole effectively ranks these structural hypotheses, with more activation being assigned to structures that are more likely given the input and less activation being

assigned to structures that are less likely given the input. An implicit assumption in most constraint-based accounts is that syntactic structures compete for activation, similar to what happens at the level of word processing in accounts of lexical access like TRACE (the competition assumption is made explicit in some versions of constraint-based processing accounts). The second critical difference between the garden path and constraint-based parsers is that the garden path parser relies solely on word category information for its inputs, but constraint-based parsers can draw on a much wider variety of cues to decide what structures to build and the relative emphasis to place on each alternative structure. Finally, constraint-based parsers are often referred to as *one-stage* models because lexical, syntactic, and semantic processes are all viewed as taking place simultaneously (as opposed to lexical processing preceding syntactic processing preceding semantic processing, which is the general approach taken by two-stage models).

The following sections explain how constraint-based parsers work and describe evidence supporting the idea that human sentence parsing processes are affected by multiple sources of information in addition to word category information.

### Story context effects

To start with, let's look at a set of studies that caused big problems for the classic garden path theory (Altmann, Garnham, and Dennis, 1992; Altmann et al., 1994; Altmann and Steedman, 1988; Crain and Steedman, 1985; Grodner et al., 2005; but see Dempsey and Christianson, 2022). Recall that the garden path parser only pays attention to word category information during its initial attempts to build a syntactic structure for a sentence. If that is true, then information that appears in preceding sentences should have *no* effect on the initial processing of a given sentence.

Let's look at sentence (11)—*The burglar blew up the safe with the rusty lock*—again. When would someone want to say something like this? In particular, why add the information about the safe having a rusty lock? Usually, speakers would add this information because they want to distinguish between one safe (that has a rusty lock) from some other safe or set of safes (that do *not* have rusty locks). But when sentence (11) appears all by itself, listeners have no direct indication that there could be more than one safe. The sentence only mentions one safe, and the definite article *the* strongly implies that there really is only one possible safe (otherwise, the speaker would say *a safe*). So, whether the syntactic structure of sentence (11) is complicated or not, the sentence creates challenges for listeners. In particular, when listeners get to *rusty lock*, they need to revise some of their semantic assumptions. They have to change from assuming only a single safe to assuming at least two safes, and they have to assume that the implicitly introduced safe or safes do not have rusty locks. These semantic changes must be made regardless of the syntactic structure that listeners initially build for the sentence.

If that is all true, can we do anything to make sentence (11) easier, without changing its syntactic structure? The answer is, yes we can. We could tell people ahead of time that there is more than one safe, using a mini-story like (17):

- (17) The burglar was planning his next job. He knew that the warehouse had two safes. Although one was brand new from the factory, the other one had been sitting out in the rain for ten years. *The burglar blew up the safe with the rusty lock.*

What should happen if this mini-story ended with sentence (11)? According to garden path theory, sentence (11) should still be hard to process because, regardless of what

happens in the mini-story, the syntactic structure that you need for sentence (11) is still complicated and hard to build. But according to the *referential context* account (a specific version of constraint-based parsing theory), the parser can use contextual information to decide which syntactic structure it will favor at a given point in time. The referential context account says, “If you have a choice of structures, build the syntactic structure that is most consistent with your current semantic assumptions. If you have a choice of structures, build (or give the most activation to) whichever one allows referring expressions to be unambiguous.” This means that sometimes the parser will build a more complicated syntactic structure when a simpler one is licensed by the grammar and consistent with the input.

Sentence (11) starts by saying *The burglar blew up the safe ...* As soon as listeners get to *the safe*, they try to figure out what *the safe* refers to. Notice that the context in the mini-story has introduced two safes—a new one and an old one. By itself, *the safe* could refer to either of these two safes. Thus, listeners need additional information to figure out which of the two safes the NP *the safe* is supposed to point to. If listeners attach *with the rusty lock* to *the safe*, that will create a phrase that is semantically unambiguous and that fits well with the preceding story context. If they build the simpler syntactic structure, *the safe* will remain ambiguous—it could refer to either of the safes introduced previously in the story. Referential theory predicts that, in the context of stories like (17), comprehenders will build the more complicated structure rather than the simpler one for sentences like (11). As a result, sentences like (11) should be very easy to process despite their complicated syntax when they appear in stories like (17). This prediction was confirmed when people’s reading times were measured. When sentence (11) appeared by itself, people slowed down when they read *the rusty lock*. When sentence (11) appeared in the context of story (17), people did *not* slow down when they read *rusty lock*. Thus, contrary to what the garden path theory predicts, the parser does seem to pay attention to information that context makes available at least some of the time to make decisions about which syntactic structure to build for a new sentence.

### Subcategory frequency effects

The garden path parser uses only word category information to make initial decisions about which syntactic structures it will build. But words can provide more information than that. For example, consider the verbs *took* and *put*. Both of these words belong to the same syntactic category—verb. But, other than having different meanings, are the two verbs equivalent? One way to approach that question is to see what kinds of syntactic structures the two verbs can be part of. Let’s start with *took*. Can *took* appear without anything following it?

(18) Dr. Phil took.

Most people would say that sentence (18) sounds odd. So let’s mark it with an asterisk to show that it is odd.

\*(18) Dr. Phil took.

What if we add a NP after *took*?

(19) Dr. Phil took a nap.

Much better! So, we conclude that *took* is the kind of a verb that needs a *post-verbal argument*. Specifically, *took* needs to have a *direct object*, in this case *a nap*. In technical terms, we call verbs like *took* “*obligatorily transitive*” (transitive verbs must have a post-verbal, direct-object argument).

How about *put*?

\*(20) Dr. Phil put.

That's odd. How about (21)?

\*(21) Dr. Phil put a book. Still odd. How about (22)?

(22) Dr. Phil put a book on the shelf.

Fine. So, *took* and *put* are similar in that neither one can appear all by itself without anything coming after, but they are different in other ways. *Took* is fine with just a direct object, but *put* requires both a direct object and a goal. Thus, they are both in the category verb, but they belong to different *subcategories*, because they have different requirements for different kinds of partners (sometimes called *arguments* or *complements*), and so different requirements for syntactic structures. (See if you can draw the structure for the VP when it has a direct object and when it has both a direct object and a PP goal argument. Ask your professor for help if you get stuck.)

Verbs like *took* and *put* are fairly picky about the kinds of complements they need and the kinds of syntactic structures they can appear in. Other verbs are more flexible. Consider the verb *was reading*. It can appear without any post-verbal arguments at all, as in (23), where it is *intransitive*:

(23) Dr. Phil was reading.

It can appear with a direct object, as in (24), where it is transitive:

(24) Dr. Phil was reading a story.

It can appear with a direct object and an *indirect object*, as in (25), and then it is *ditransitive*:

(25) Dr. Phil was reading a little girl a story.

So, *was reading* has a number of subcategory possibilities, including intransitive, transitive, and ditransitive; and each of these subcategory possibilities is associated with a different syntactic structure. There are, in fact, many verbs that are flexible in this way. (See if you can think of a few.)

Constraint-based parsers differ from two-stage parsers like the garden path parser because constraint-based theory says that structural information is associated with individual words in the lexicon and this information influences which structural hypotheses will be pursued as sentences are being processed. In particular, a constraint-based parser will use subcategory information to determine which structural analysis to favor when more than one structure is consistent with the input. How does this work? Consider the following sentence fragment:

(26) The student saw the answer ...

This fragment could continue

... to the last question.

In that case, *the answer* is the direct-object argument of *saw*, and the sentence should be structured as in (27).

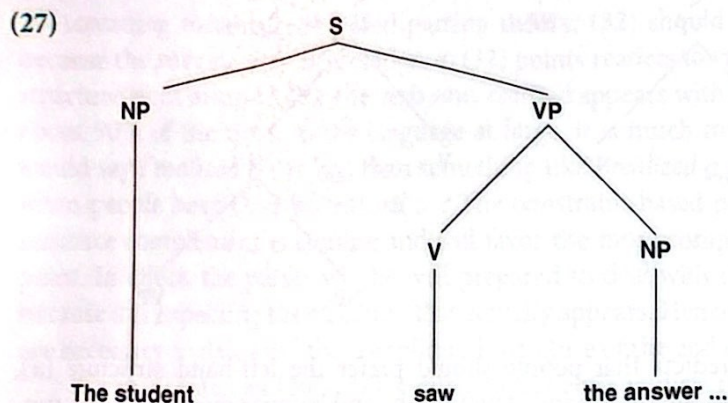

But in sentence (28)

(28) The student saw the answer ...

continues with

... was in the back of the book.

In that case, *the answer* does not represent the direct object of *saw*. Instead, *the answer* is the subject of the verb *was*, and the sentence should be structured as in (29). In sentence (28), the part *the answer was in the back of the book* is called a *sentence complement*. *The answer was in the back of the book* is a sentence complement because it really is a sentence that could appear all by itself and because the whole thing is the post-verbal complement of *saw*.

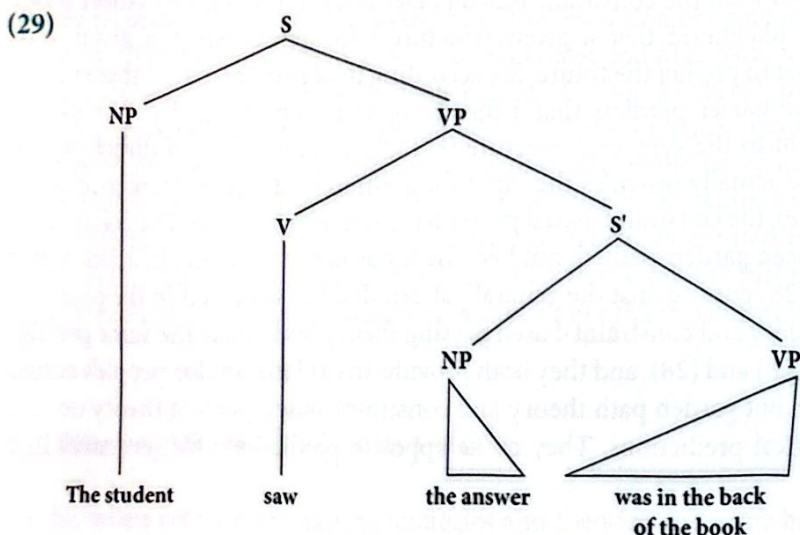

So, when comprehenders get to “the answer” in (26) and (27), they face a choice between the structures in (30).

(30) (a)

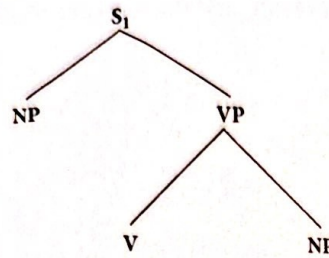

(b)

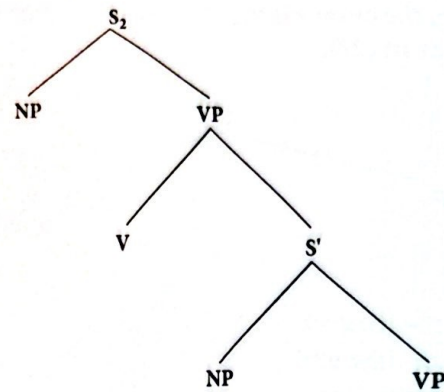

Garden path theory predicts that people should prefer the left-hand structure (a), because it is simpler than the right-hand structure (b) and because pursuing that structure allows comprehenders to continue working on the current VP. So garden path theory predicts that sentences like (28) should be harder to understand than sentences like (26), and this is true in general. Constraint-based theory also predicts that (28) should be harder than (26), but for a different reason. It turns out that both theories are correct in this instance—sentences like (28) really are harder to process than sentences like (26) (Frazier and Rayner, 1982; Pickering and Traxler, 1998).

Constraint-based theory assumes that people pay attention to *subcategory preference* information. Subcategory preference information reflects the likelihood that a given structure and a given verb go together. Consider the verb *saw* again. Suppose you know that 9 times out of 10 in the past *saw* was followed by a direct object (as in (26)). Suppose that, after you heard *The student saw* but before you got the next word, someone would let you bet about what structure the sentence as a whole would have. Would you bet on direct object or on something else, sentence complement perhaps? If you bet (or predicted) that the next thing would be a direct object, you would be right in the long run 90% of the time (and you would become rich).

Essentially, this is what the constraint-based parser does. It takes information about the past—e.g. the likelihood that a given structure will appear when a given verb appears—and uses it to predict the future. So, according to constraint-based theory, (28) is hard because the parser predicts that a direct object is coming, and so the parser assigns more weight to the syntactic structure that allows *saw* to have a direct object. When the sentence actually provides the input for a different structure (sentence complement in this case), the constraint-based parser has to change its mind. The constraint-based parser has been garden-pathed, not because it has used the wrong heuristics, but because sentence (28) goes against the general pattern that has occurred in the past.

Garden path theory and constraint-based parsing theory both make the same prediction for sentences (26) and (28), and they both provide an explanation for people's actual observed behavior. But garden path theory and constraint-based parsing theory do not always make identical predictions. They make opposite predictions for sentences like (31) and (32):

(31) Dr. Phil realized his goals early on.

(32) Dr. Phil realized his goals were out of reach.

The syntactic structures we need for (31) and (32) are the same structures that we need for the corresponding (26) and (28). In (31), *his goals* is the direct-object argument of *realized*, so it has the same structure as (26). In (32), *his goals* is the subject of a sentence complement (*his goals were out of reach*), so it has the same structure as (28). Garden path theory predicts that (32) should be harder than (31) (for the reasons laid out earlier), but constraint-based theory predicts that (32) should be just as easy to process as (31). Why is that?

According to constraint-based parsing theory, (32) should be just as easy as (31) because the subcategory information in (32) points readers toward the correct syntactic structure right away. Unlike the verb *saw*, *realized* appears with a sentence complement about 90% of the time. In the language at large, it is much more likely that someone would say *I realized I was late*, than something like *I realized a profit*. So, what happens when people hear *Dr. Phil realized ...*? The constraint-based parser will predict that a sentence complement is coming and will favor the more complicated structure at that point. In effect, the parser will be well prepared to deal with the rest of sentence (32) because it is expecting the structure that actually appears. Hence, no structural revisions are necessary to deal with the complicated structure of the end of sentence (32).

So, across sentences (26)–(32), garden path theory predicts that (26) and (31) will be easy to process and (28) and (32) will be hard to process. By contrast, constraint-based parsing theory predicts that only sentence (28) will be hard to process, because the structure that the parser predicts is different from the structure that actually appears only in that case.

Eye-tracking and self-paced reading experiments showed that only sentences like (28) cause comprehenders difficulty (Garnsey et al., 1997; Trueswell et al., 1993). This can be explained if we assume that the parser keeps track of how often specific verbs go together with different syntactic structures and that it uses this information very quickly when it is making decisions about which structural options to pursue. Findings like these also support the idea that the parser is trying to anticipate which structures it is likely to encounter in the near future, and that subcategory information is one of the sources of information that the parser uses to make its predictions.

When comprehenders demonstrate sensitivity to subcategory preference information (the fact that some structures are easier to process than others when a sentence contains a particular verb), they are behaving in ways that are consistent with the *tuning hypothesis*. The tuning hypothesis says, “that structural ambiguities are resolved on the basis of stored records relating to the prevalence of the resolution of comparable ambiguities in the past” (Mitchell et al., 1995, p. 470; see also Bates and MacWhinney, 1987; Ford et al., 1982; MacDonald et al., 1994; Seidenberg and MacDonald, 2018). In other words, people keep track of how often they encounter different syntactic structures, and when they are uncertain about how a particular string of words should be structured, they use this stored information to rank the different possibilities. In the case of subcategory preference information, the frequencies of different structures are tied to specific words—verbs in this case. The next section will consider the possibility that frequencies are tied to more complicated configurations of words, rather than to individual words.

### *Cross-linguistic frequency data*

So far, when considering parsing strategies and theories, the focus has been entirely on English. However, considerable work has been done in other languages that helps illuminate how people parse and interpret sentences. One line of *cross-linguistic research* (research

that compares how different languages are processed) has focused on the extent to which structural preferences in different languages match the frequencies with which different structures occur in those languages. For example, Spanish speakers can use a relative clause to modify a preceding noun. Sentence (33) is globally ambiguous because the relative clause “who was standing on the balcony with her husband” could go with either “(female) servant” or “actress” (from Cuetos and Mitchell, 1988; see also Dussias et al., 2019):

(33) Alguien disparo contra la criada de la actriz que esta ba en el balcon con su marido.

“Someone shot the (female) servant of the actress who was standing on the balcony with her (male) spouse.”

(34) Alguien disparo contra el criado de la actriz que esta ba en el balcon con su marido.

“Someone shot the (male) servant of the actress who was standing on the balcony with her (male) spouse.”

Sentence (34) is temporarily ambiguous because, although “who was standing on the balcony” could describe either “(male) servant” or “actress,” the end of the relative clause (“with her spouse”) ties the relative clause definitely to the second of the two nouns.

For sentences like (33) and (34), English readers exhibit a preference to attach the relative clause to the second of the two nouns (“actress”), but Spanish speakers exhibit a preference to attach the relative clause to the first of the two nouns (“servant”) (Carreiras and Clifton, 1993, 1999). French speakers also appear to prefer to attach the relative clause to the first noun in equivalent French sentences, while Italians and Germans prefer the second (Cuetos et al., 1996; Mitchell et al., 1995). Why should there be this difference in structural preferences across languages? One possibility is that the frequency with which the structures appear differs across languages. While attachment to the first noun appears to be the more frequent option in Spanish and French for sentences like (33) and (34), English and Italian appear to pattern the other way.

Although it would be possible to tie the likelihood of being modified to individual nouns, it appears that structural frequency information is being associated with larger elements—configurations of nouns. (For example, people are more likely to modify a noun like *thing* than a more specific noun like *apple*, and people almost never modify proper names. So you’re far more likely to hear plain old *Dr. Phil* than *The Dr. Phil who is standing right over there talking about sex with Rush Limbaugh*.) The idea that frequencies are associated with groups of words is supported by the fact that near exact translations of the same sentences like (33) and (34) have been used in different languages, so the same nouns are represented in the different studies. If the structural preferences were associated with individual nouns, they should be pretty similar across languages.

Experimental outcomes for sentences like (33) and (34) show that frequent structures are easier to process than less frequent structures. This is compatible with constraint-based accounts’ claims that people keep track of how often they encounter particular kinds of sentences, and that they favor structures they have encountered more often in the past when a new sentence can be structured in more than one way. However, there is a possible counterexample from Dutch. Marc Brysbaert and Don Mitchell measured Dutch speakers’ eye movements while they read the Dutch equivalents of (33) and (34) (Brysbaert and Mitchell, 1996). The eye movements indicated that Dutch speakers had more trouble interpreting the test sentences when the relative clause went with the first noun than when it went with the second noun. But when researchers looked at a database of Dutch sentences (that came from newspaper and magazine articles), they found that relative clauses went with the first noun more often than they went with the second.

So, the more frequent structure appeared to be more difficult to process, contrary to what constraint-based and other frequency dependent parsing theories would predict. However, when other researchers analyzed the test sentences and the sentences from the database, they found that semantic factors like animacy and concreteness were more important than position in determining where the modifying relative clauses should go (Desmet et al., 2006). So, when more *fine-grained* information was taken into account, reading time could be predicted by detailed frequency information.

The cross-linguistic investigation of relative clause attachment raises a further important issue: How does the parser decide whether something is frequent or infrequent? If we just count all sentences, simple active voice sentences will be the most frequent (example active voice sentence: *John kissed Mary*). The parser should therefore favor the direct-object interpretation of any sentence that starts with a NP and a verb phrase. But if we start counting up which structures go with an individual verb, then the parser should favor the sentence complement interpretation of any sentence that starts with a NP followed by the verb *realized* followed by another noun. But if we start counting up the likelihood of specific verb–noun combinations, then the parser should switch back to favoring the direct-object interpretation of any sentence that starts with a noun, the verb *realized*, and the noun *goals*. Likewise, if we start factoring in animacy, then any sentence that starts with an inanimate noun should reduce the likelihood of a simple, active structure.

This problem goes by the name *the grain size problem*. Languages offer us multiple levels of analysis (different *grains*), people can potentially keep track of statistics at any level of analysis, and the degree to which a structural alternative is preferred can differ at different grains. One solution to the grain size problem is to suggest that the parser does not keep any statistics at all (as some two-stage models claim). If the parser does not try to estimate likelihood, and instead bases its decisions on other criteria (like *simplicity* or *recency*), then there is no reason for us to worry that different frequencies apply at different grains.

Another solution is to suggest that the parser keeps track of statistics at different grains, and that it combines data from different grains to arrive at an overall estimate of likelihood. So, in our example involving *realized*, the parser will give some weight to the fact that the most common structure in the language is subject-verb-object, it will also give some weight to the fact that the most likely structure for any sentence with the verb *realized* in it is the sentence complement structure, but if it gets *realized* followed by *goals*, the parser will pay attention to the fact that, at this very fine grain, *goals* is a really good direct object for *realized*, and will therefore boost the activation of the syntactic structure that goes with that interpretation.

## Semantic effects

So far, we have seen how a constraint-based parser could use story context information and subcategory information to anticipate upcoming syntactic structure. Another source of information that the parser could rely on is the semantic (meaning) information associated with specific words in sentences (as in the *realized his goals* example). Again, this is a point where constraint-based theory differs from garden path theory because garden path theory says that the parser ignores semantic information as it is making its initial structural decisions. To see how that works, let's look at a kind of sentence called a *reduced relative*:

(35) The defendant examined by the lawyer went to prison.

(35) is called a reduced relative because it contains a relative clause *examined by the lawyer* that modifies the meaning of the preceding NP *The defendant* (“Which defendant are we talking about?” “The one examined by the lawyer.”). The sentence can be made easier to process if we introduce the relative clause with a *relativizer*. In (36) the relativizer *who* unambiguously marks the start of the relative clause.

(36) The defendant who was examined by the lawyer went to prison.

Numerous studies have shown that sentences like (35) are harder to process than sentences like (36) (e.g. Clifton et al., 2003; Ferreira and Clifton, 1986). Why is that? In general, reduced relatives are difficult to process because listeners have a hard time figuring out that they are dealing with a relative clause rather than something else. Why do they have trouble identifying the relative clause? One reason is that the beginning of the reduced relative clause looks like a regular old *main clause*. (Main clauses consist of the grammatical subject of the sentence, the main verb of the sentence, and the arguments and modifiers that go with the main verb. Subordinate and relative clauses provide additional information about the main clause or individual words that appear in the main clause.) So, while processing *The defendant examined ...* listeners might begin to build a syntactic structure that is appropriate for a main clause continuation. If so, they would be ill prepared to deal with the actual continuation in (35), but they would be well prepared if the sentence continued as in (37):

(37) The defendant examined the photographs.

The structural choices that the parser faces are represented in (38).

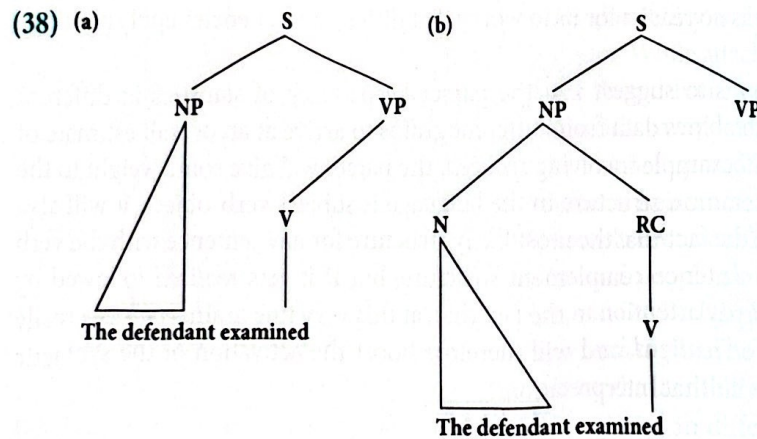

(38a) shows the structure that you need for the main clause interpretation. (38b) shows the structure that you need for the relative clause interpretation.

Notice that the structure in (38b) is more complicated than the structure in (38a), and so garden path theory predicts that people will prefer the structure in (38a)—the main clause structure. As a result, people should have trouble dealing with a sentence that requires the more complicated structure in (38b). Constraint-based parsing theory also predicts that the reduced relative clause in (35) will be hard to process, but for a different reason. Constraint-based theory says that the problem of figuring out that *examined* is part of a relative clause is made worse by the fact that *defendant* refers to a person, and people are very likely to *examine* things. That is, *defendant* falls in the category of *animate* things. *Animate* things, like people, animals, and fish, can move around, have goals, initiate actions, and so forth. *Inanimate* things, like rocks, trees, and houses, do not move around, do not have goals, and do not initiate actions. Most of the time, when a sentence

starts with an animate entity, the animate entity is responsible for starting the action described in the sentence (as in (37)).

The technical name for someone or something that starts an action is *agent* or *thematic agent* (Jackendoff, 1990). It is less likely that an animate entity that starts a sentence will be the recipient of an action that is initiated by someone else. The technical names for someone or something that is the target of an action are *theme*, *experiencer*, or *recipient*. (An exception to the general pattern of an animate initial noun being the agent occurs in *passive* sentences, like *The defendant was examined by the lawyer*. But here, the sentence provides abundant structural cues that clarify the *patient* status of the initial noun *defendant*. See if you can spot some of the cues that the passive provides.)

According to constraint-based parsing theory, when people hear *The defendant examined ...*, they know that *defendant* is animate, they assume that the animate *defendant* will initiate the action, and *examined* provides them with the action that the *defendant* is initiating. When they actually get *by the lawyer*, all of those assumptions need to be undone. *The defendant* isn't the initiator of the *examining* action, the defendant is the recipient. *The defendant* isn't examining anything, but is being examined. On top of all of that semantic (meaning) revision, it turns out that the parser's structural assumptions were also wrong. Chaos! The poor listener has been garden-pathed in a major way and has to do a lot of work to clean up the mess.

(An even more difficult reduced relative than sentence (35) is, *The editor played the tape was furious*. Astonish your professors by explaining to them why that one is harder than sentence (35).)

If semantics is the driving factor that turns reduced relatives into mental train wrecks, it should be possible to use semantic information to make sentences like (35) easier to process. How might we do that? Because the train wreck starts with assumptions about *the defendant*, we could start by triggering a different set of assumptions. We can do that by starting the sentence with an inanimate noun, like *evidence*, as in (39):

(39) The evidence examined by the lawyer was complicated.

Because *evidence* is inanimate, it is not a good agent and is highly unlikely to initiate the action in the sentence. But it is a really good thematic patient. So, when listeners hear *The evidence examined ...*, they should heavily discount the possibility that they are looking at a sentence with a main-clause structure like (37). The parser should immediately rule out the possibility that *examined* is the main verb of the sentence and it should choose a different structure right away. By using information about the meaning of the initial noun (is it animate or inanimate?), the parser can avoid building the wrong structure for the sentence. If this allows the parser to avoid making bad semantic and structural assumptions, then people should not have very much trouble processing sentences like (39).

In fact, although there is some uncertainty about how quickly semantic information influences the structure-building process, sentences like (39) with inanimate initial nouns are easier to interpret than sentences like (35) with animate initial nouns—having an inanimate initial noun like *evidence* does reduce the overall processing difficulty that the reduced relative imposes on the comprehender (Trueswell et al., 1994; Clifton et al., 2003). (Researchers agree that animacy either helps comprehenders get to the right syntactic structure straight away, or it helps them dump a bad structure faster so that they can start building the right structure faster after building the wrong structure, or both. Note also that if the animacy experiments show that comprehenders use animacy to avoid building bad structure, then findings like these are problematic for garden path parsing theory. The garden path parser ignores semantics when it makes its structural decisions, so it should make the same structural choices for sentences with animate initial nouns and sentences with inanimate initial nouns.)

## Prosody

When people speak sentences, they produce sequences of words, and they modulate the speed, loudness, and pitch that they speak at depending on what roles the words are playing in the sentence. The speech information that identifies specific words is called *segmental* information (where a “segment” is any discrete unit that can be identified, including phonemes, syllables, and words). The information that correlates with grammatical role and other discourse functions is called *suprasegmental* information (“suprasegmental” means the speech pattern extends across more than one segment), and this is normally what is referred to when language scientists use the term *prosody* (Speer and Blodgett, 2006; Speer and Foltz, 2015).

People who study prosody categorize speech patterns into two general classes. *Nonlinguistic* prosody consists of those aspects of speech that provide cues to the speaker’s general mental state. Is the speaker happy, angry, or depressed? The tone and tempo of the speaker’s output will differ depending on how the speaker is feeling at the moment. *Linguistic* prosody consists of those aspects of speech that provide cues to how the words are organized into phrases and clauses. For example, stress—how loud particular speech segments are spoken—can indicate whether someone is speaking a compound noun or whether someone is speaking an adjective and a noun. If someone says *green HOUSE*, it’s likely that they are talking about a house that’s been painted green. If someone says *GREEN house*, they are probably talking about a place where you grow plants when it’s too cold outside. Another example is the difference between statements and questions. Suppose someone says *John wants a hamburger* with a rising tone at the end. Normally, a speaker would use that prosodic cue to indicate uncertainty—the speaker is asking a question. If the speaker pronounces the same sentence with a falling tone at the end, that usually indicates that the speaker is making a statement—i.e. the speaker knows what John wants.

Prosody can provide cues that help the parser to construct the correct syntactic structures when the input is syntactically ambiguous. For example, consider sentence (40) (from Speer and Blodgett, 2006, p. 506):

(40) The professor said the student had on socks that did not match.

This sentence could be pronounced in different ways with pauses in different locations. Try speaking the sentence with a big pause after *said*, and no big pauses anywhere else. If you pronounce the sentence that way, who has the mismatched socks, the professor or the student? Now try speaking the sentence with two big pauses, one right before *said* and one right after *student*. Now it should be someone else who is having a bad socks day.

Pauses are a good cue to phrase structure, because words that go together to make a phrase are usually pronounced together without any major pauses or breaks. This does not always happen, however, as sometimes speakers make mistakes or are dysfluent—speech is full of false starts, “ums,” “ahs,” “you knows,” and other verbal tics that can interfere with the clean packaging of prosodic cues and phrase structure. So, while prosodic cues can be very useful, they are not always available, and when they are, they are not always 100% valid. Therefore, one question language scientists have asked is: How do listeners rely on prosody when they are making syntactic structure decisions? This section will review some of the studies that indicate that, when prosodic cues are available, listeners use them very quickly to choose between alternative structural possibilities.

Because naturally occurring speech has a lot of syntactic and prosodic properties that are not easy to control for in an experiment, language scientists often use carefully constructed utterances to test how listeners respond to prosodic cues. Using carefully planned and recorded speech allows them to control for nuisance variables. Research

who study prosody have also created a very sophisticated analytical tool called the *ToBI* (Tones and Breaks Index) system that allows them to clearly identify the prosodic cues that are present in any given utterance. With these tools in hand, researchers can systematically manipulate the prosodic cues in sentences that are controlled with regard to their syntactic structures and meaning. They can then present their sentences to listeners in situations that allow them to carefully observe the listeners' behavior. Researchers draw inferences about how prosody affects the meaning assigned to globally ambiguous sentences and determine how quickly listeners combine prosodic and syntactic information as they interpret sentences.

Prosodic cues appear to strongly influence the interpretation of some sentences that have globally ambiguous syntactic structure. For example, consider sentence (41) (from Carlson et al., 2001):

(41) Susie learned that Bill telephoned after John visited.

This sentence is globally ambiguous because *after John visited* could tell us when Susie learned something about Bill, in which case the phrase *after John visited* attaches to the verb *learned*. Alternatively, the phrase *after John visited* could tell us when Bill telephoned, in which case it attaches to *telephoned*. If there is a relatively large pause between *Bill* and *telephoned*, listeners are likely to judge that *after John visited* goes with *telephoned*. If there is a relatively large pause after *telephoned*, listeners are likely to judge that *after John visited* goes with *learned*.

Sentences like (41) are somewhat artificial, because they have been digitally altered, but similar effects occur under more natural circumstances. For example, researchers observed naive participants who came into the lab and took part in a game (Schafer et al., 2000). The game involved game pieces that came in different shapes and colors. A "driver" instructed a "slider" how to move the pieces around the board. The trick was that the driver knew where the pieces were supposed to end up, but only the slider knew the location of bonuses (cookies) and penalties (ravenous goats). The driver and slider cooperated to earn points. The researchers elicited temporarily ambiguous sentences from the participants by giving them a list of scripted sentences that they could use to play the game, such as (42) and (43):

(42) When that moves the square should land in a good place.

(43) When that moves the square it should land in a good place.

Drivers spontaneously produced prosodic cues that helped to disambiguate the sentences (e.g. they would pause after *moves* when speaking sentences like (42) and after *square* in (43)). Next, the researchers deleted everything after the word *square* and played the truncated sentences to a new set of participants. These participants were asked to guess how the sentences would continue. They were able to accurately predict what ending the original speakers had used, and this indicates that the listeners were using prosodic information to choose between alternative syntactic structure possibilities.

Other research addresses the question of how quickly listeners use prosody to make structural decisions. One such study involved sentences like (44) and (45) (Kjelgaard and Speer, 1999; see also Snedeker and Trueswell, 2003):

(44) When Roger leaves the house is dark.

(45) When Roger leaves the house it's dark.

(44) is a garden path sentence very similar to (7). (45) is also temporarily ambiguous, but it is normally easier to process than (44) because the listener's syntactic assumptions for

(45) match the structure that the sentence actually requires. We could help the listener deal with sentence (44) by inserting a big pause after the word *leaves* (try pronouncing the sentence that way). We could make things more difficult for the listener by pronouncing *leaves the house* all together without any pause between *leaves* and *the house*, and by putting in a big pause before *is* (try pronouncing the sentence that way—it will probably sound strange to you). There are other prosodic cues that can help the listener deal with (44). Those cues involve changing the average pitch of different parts of the utterance and the length or duration of the words in the utterance. (See Speer and Blodgett, 2006, for a more complete description.) The same prosodic changes can be made to sentences like (45).

When the prosodic cues point listeners toward the correct syntactic structure, the prosody is said to be *cooperating*. When the prosodic cues point listeners toward the incorrect syntactic structure, it is said to be *conflicting*. Researchers can measure how hard it is to process sentences like (44) and (45) using a variety of experimental tasks. They can ask listeners to press a button when they have figured out what the sentence means after they hear it. Alternatively, they can ask listeners to respond to a visual target word after listening to most of the sentence. For example, listeners might be asked to name (speak) the word *is* after listening to *When Roger leaves the house*. If listeners have been building the correct syntactic structure for the beginning of the sentence, it should be easier to say *is* than if they have been building the wrong structure. The same predictions apply for sentence (45). Participants' behavior on both of these tasks showed that they used prosodic cues very quickly to make structural decisions in sentences like (44) and (45). Listeners pressed the "Got it" button faster when the sentences had cooperating prosody than when they had conflicting prosody; and they pronounced the syntactically disambiguating main verb (*is* or *it's*) faster for cooperating than conflicting prosody as well.

### Visual context effects

Previously, we have seen that information in a story, and the way a new sentence fits into the story, can affect the structural choices that the parser makes. This section will review further evidence that syntactic parsing can be influenced by information from outside the language processing system. Specifically, the information available in a visual scene can increase the parser's preference for a complex syntactic structure. To see how this works, consider sentence (46):

(46) The girl placed the apple on the towel in the box.

(46) is a garden path sentence because comprehenders interpret the first PP *on the towel* as the goal of the placing action (i.e. they think that the girl put the apple on the towel). To interpret the sentence as it was intended, comprehenders have to attach the first PP to *the apple* (as in *Which apple did the girl place? The apple (that was) on the towel*). In that case, *on the towel* is a source rather than a goal location. Garden path theory says that sentences like (46) are hard to process because the minimal attachment heuristic makes the parser adopt the wrong syntactic structure. Constraint-based parsing theory and referential theory say that sentences like (46) are hard to process because, when the sentence appears by itself, nothing tells the listener that there might be more than one apple and so there is no obvious reason to treat *on the towel* as information that discriminates between the explicitly mentioned apple and some other set of unmentioned apples. We have seen that mentioning more apples in a story context can make sentences like (46) easier to process, but is there any other kind of context that can have a similar effect?

To answer that question, Mike Tanenhaus and his colleagues conducted a study where they manipulated what listeners were looking at as they listened to and tried to understand sentences like (46) (Tanenhaus et al., 1995). This study used the *visual world* experimental method (or paradigm). In the visual world paradigm, participants wear an eye-tracking device that shows researchers where they are looking during an experiment. Real objects are placed on a table in front of the participants. Participants listen to sentences about these objects and they respond to the sentences by moving the objects around. The researchers can manipulate characteristics of both the visual display and the sentences to see what effect this has on participants' eye movements. By analyzing participants' eye movements, researchers can draw conclusions about how the participants interpreted the sentences.

For example, consider the displays in Figure 4.2. The left-hand display contains only a single apple, and that apple is on a towel. The left-hand display also has an empty towel and a box. The right-hand display contains two apples. One of the apples is on a napkin and the other apple is on a towel. There is also a towel with nothing on it. So, both displays have an empty towel that could match up with the goal interpretation of *on the towel*. Because it has two apples, the right-hand display is the visual equivalent to the story that mentioned two safes. While participants looked at either the left-hand display (the one-apple display) or the right-hand display (the two-apple display), they listened to a sentence that said, *Put the apple on the towel in the box*. The critical thing that the researchers wanted to know was: Where did participants look when they heard *on the towel*? If participants interpreted *on the towel* (incorrectly) as the goal of *Put the apple*, then they should look at the empty towel. If they interpret *on the towel* (correctly) as modifying the meaning of *apple*, then they should look at the apple that is on the towel. So, what happened in the experiment?

First, let's consider what happened when the visual display only had one apple (the left-hand side of Figure 4.2). When participants heard *on the towel* in *Put the apple on the towel ...*, they were more likely to look at the empty towel than the apple. So it looks like

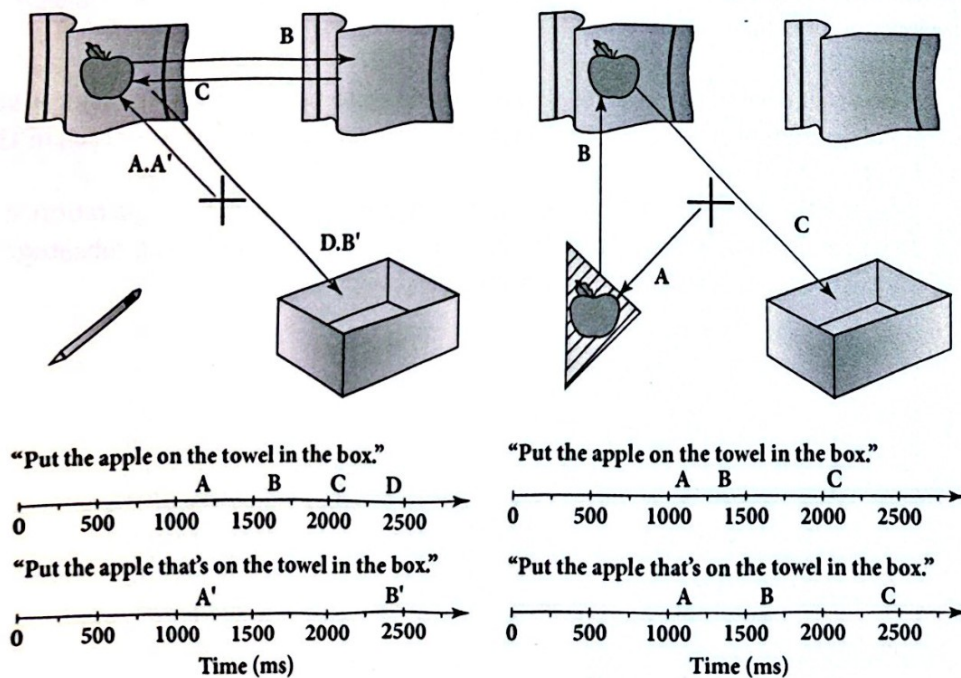

**Figure 4.2** Sample visual displays and eye-movement patterns. *Source:* Tanenhaus et al. (1995), American Association for the Advancement of Science

participants were interpreting *on the towel* (incorrectly) as a goal, rather than something that modified the meaning of *apple*.

Something very different happened when the visual display had two apples (one on a towel and one on a napkin) and an empty towel. Under these conditions, when participants heard *on the towel*, they were more likely to look at the apple that was on the towel, rather than looking at the empty towel. So, it looks like participants were (correctly) interpreting *on the towel* as going with *apple* when the visual display had two apples. That result is very similar to the story context experiment involving sentences like (11)—*The burglar blew up the safe with the rusty lock*. This new result goes beyond those previous ones, however, by showing that information from other modalities (i.e. vision) has a rapid effect on processes taking place within the language-processing system. When the display has two apples, the expression *the apple* by itself does not successfully refer to either apple. Under those conditions, participants were willing to build a more complicated syntactic structure so that they could attach *on the towel* as a modifier of the expression *the apple*, and in that case, the expression as a whole *the apple on the towel* successfully picked out one of the two apples in the display. So, the way the syntactic parser functioned was affected by what was happening in the visual system.

## Interim Summary

So far in this chapter we have seen that sentence interpretation involves a parser that makes decisions about how words in sentences relate to one another. We have looked at two different processing mechanisms that have been proposed to explain how parsing takes place. The currently available experimental evidence shows that there are some aspects of people's behavior that are not fully compatible with the garden path theory. As a result, many researchers favor one of the constraint-based versions of sentence-processing theory. If one wanted to draw a picture to represent the main assumptions that constraint-based theory makes about sentence processing, it might look like Figure 4.3. The key points to take away are:

1. A constraint-based parser can activate multiple syntactic structures simultaneously.
2. It ranks different structures based on how much evidence is available for each in the input.
3. Evidence for a given structure and its accompanying semantic interpretation can come from multiple sources, including story context, visual context, subcategory information, and the semantic properties of specific words.

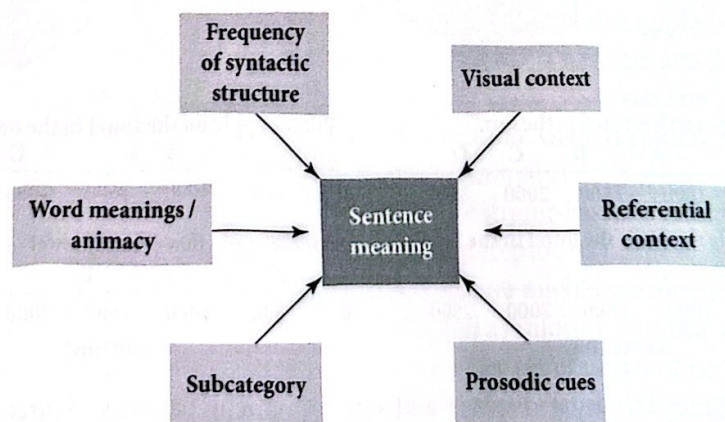

Figure 4.3 A constraint-based outlook on syntactic parsing

## PREDICTION IN SENTENCE PROCESSING

Have you ever found yourself finishing someone else's *sandwiches* sentences? Have you ever wondered how that works? Gerry Altmann certainly has. Gerry and his collaborator, Yuki Kamide, conducted a very influential study that has changed the way a lot of people think about sentence processing (Altmann and Kamide, 1990). In this study, people looked at pictures like the one shown here while listening to sentences. They had their eye movements monitored by an eye-tracker. The sentences had different kinds of verbs. In one condition, the verb had very loose requirements for a post-verb argument. "The boy will *move* ..." could plausibly continue with any of the pictured objects ("The boy will move the ball/cake/car/train" are all good). In another condition, the verb had much narrower requirements. "The boy will *eat* ..." can only plausibly continue with one of the pictured objects (the cake).

Starting with the punchline, Altmann and Kamide found that when people listen to "The boy will eat ..." their eyes move to the cake *before they hear the word cake*. Thus it appears that people use information from the verb to predict or anticipate how the sentence will continue (as opposed to waiting until the noun *cake* shows up to figure out what's going on in the sentence). Subsequent studies have investigated what, precisely, listeners are predicting (just the likely upcoming meaning, specific syntactic categories of words, the precise orthographic or phonological form, or all of these) (Brothers et al., 2015; Brothers and Traxler, 2016; DeLong et al., 2005; but see Nieuwland et al., 2018). It appears therefore that we can finish each other's *sandwiches* sentences. But how?

Some accounts propose that we use our speech production systems to predict how a sentence will continue (Pickering and Gambi, 2018; Pickering

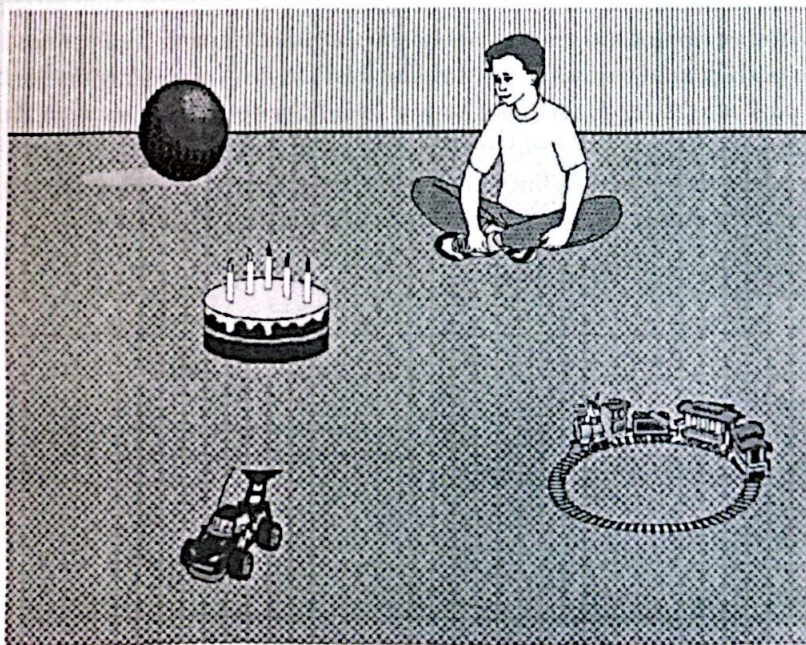

and Garrod, 2007). This account says that, as you listen to someone speak, you are building a representation of the meaning, and you can use knowledge of events to figure out how things are likely to play out in the future. Other accounts appeal more to knowledge of language patterns, without much concern for meaning (Hale, 2003, 2006). On this kind of account, your long-term memory stores information about sequences of words, so you can compute how likely different continuations are.

In the context of *The boy will eat ... cake* is highly likely; *cake* is less likely in the context of *The boy will move ...*. As a result, you are less surprised to hear *cake*, and the amount of bottom-up processing you must devote to *cake* is different in different contexts. Some accounts are hybrids, suggesting that listeners are making predictions of various kinds at various levels of representation (phonological/orthographic, syntactic, and semantic) simultaneously (Kuperberg, 2021; Wang et al., 2021).

## Argument Structure Hypothesis

One of the central claims that constraint-based theory makes about parsing is that structural information is tied to specific words in the lexicon. What does this structural information look like? Let's look at how structural information related to verbs might be represented.

One possibility is that our long-term memories contain information about phrase structure trees like those in (47) (MacDonald et al., 1994). For a verb like *was reading*, long-term memory would contain at least three phrase structure trees, one for the intransitive form, one for the transitive form, and one for the ditransitive form. But what about the dative form? Is that represented, too? If so, there would be a fourth tree, as in (48). And what if the dative form is supplemented by information about location? Do we need another tree for *was reading the book to the girl at the park*? If so, we need the structure in (49). What if we had something like this? *Dr. Phil was reading the book to the girl at the park next to the fire station that was built by generous pilgrims from Burkina Faso who liked to take long walks with their vicious pet lizards*. If we wanted to pre-store all of the structure that goes with the verb, then we would need something like (50) (and this does not even take into consideration numerous syntactic ambiguities).

(47) "was reading"

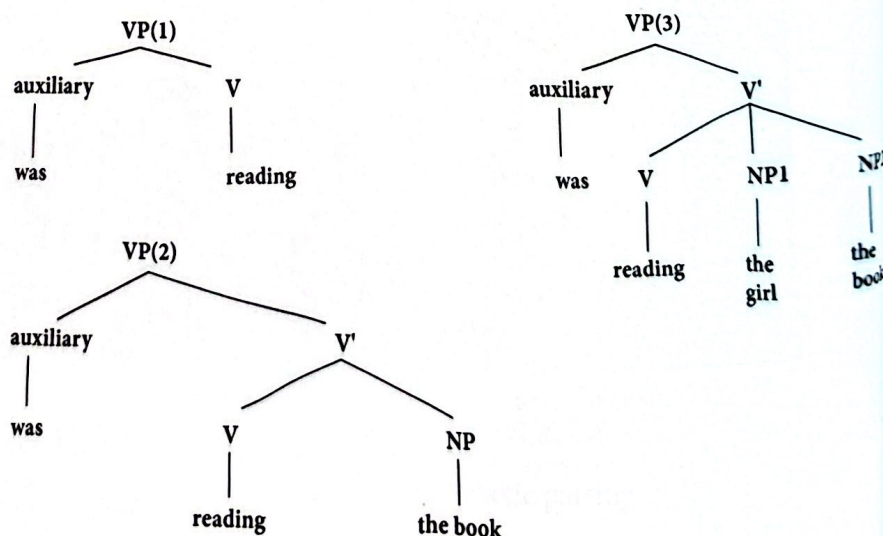

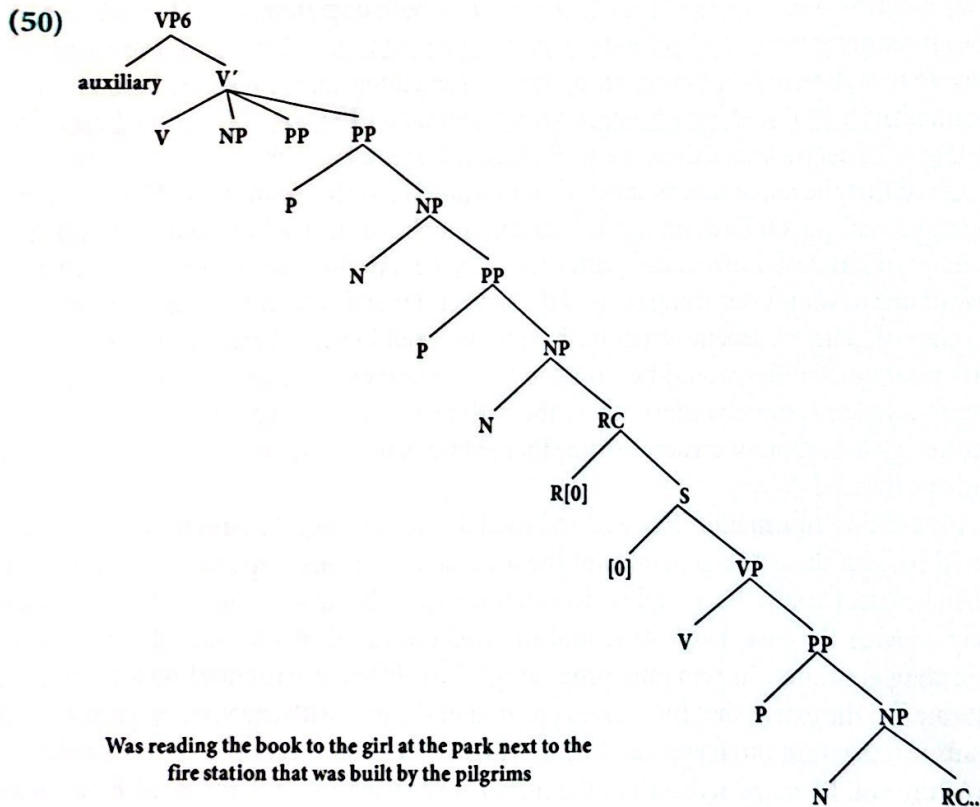
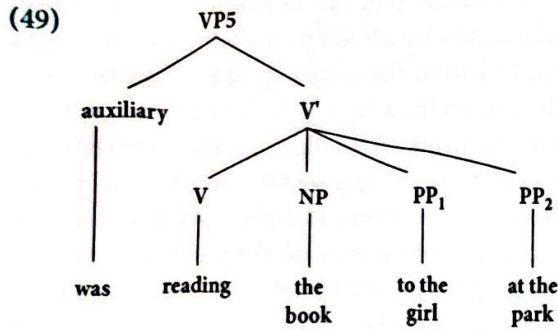
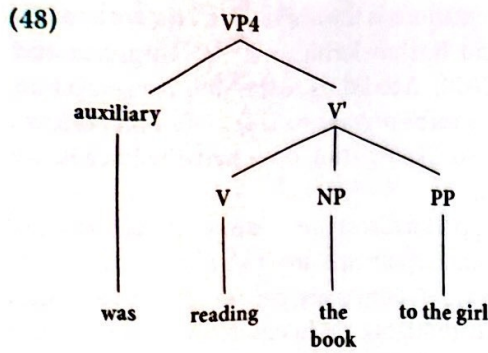

We really need a set of principles or guidelines that allows us to avoid the psycholinguistic equivalent of *the leg-shaving problem*: Where do I stop? In leg-shaving, many people adopt the principle, "I stop below the knee." This principle requires us to decide where, exactly the knee is, and that can be somewhat ambiguous, but now we at least have a clear "stop" rule, and we can proceed even if we have only a rough idea where the knee ends. Can we come up with a similar principle for verb-related syntactic structure? One

possible stop rule for storing syntactic representations is the *argument structure hypothesis* (Boland and Blodgett, 2006; Boland and Boehm-Jernigan, 1998; Tutunjian and Boland, 2008; see also Matchin and Hickok, 2020). According to the argument structure hypothesis, structural information related to a verb's *arguments* is stored in the lexicon, and everything else is computed "on the fly." So, like figuring out where the knee is, we have to work out what counts as an argument.

Linguists have identified principles that support a distinction between *arguments* and *adjuncts*. Although there is not 100% agreement, arguments are (roughly speaking) linguistic partners that a word absolutely must have. Adjuncts are partners that a word can have, but does not need. Arguments are usually thought of as being elements of meaning that a word needs to express a complete thought. These elements of meaning are usually explicitly expressed in the sentence, but sometimes they can be omitted. For example, the verb *eating* is thought to require an object (you have to eat something in order to eat), but that semantic argument can be omitted from the actual spoken sentence if the speaker wishes to focus the listener's attention on the action, as in *Dr. Phil was eating*.

Verbs can have between zero and four arguments. Verbs like *rained* and *snowed* have zero arguments (Jackendoff, 2002). Because languages require sentences to have grammatical subjects, speakers include a meaningless pronoun as a placeholder when they use zero-argument verbs in sentences, as in, *It rained. It snowed*. Verbs like *sneezed* have one argument, as in *Dr. Phil sneezed*. (The arguments are underlined in the examples.) Verbs like *devoured* have two arguments, as in *Dr. Phil devoured the sandwich*. (And in the case of *devoured* all of the arguments must be included in the actual spoken sentence. \**Devoured the sandwich* and \**Dr. Phil devoured* are both ungrammatical.) Verbs like *put* have three arguments (*Dr. Phil put the sandwich on the plate*). Verbs like *bet* or *wagered* have four arguments—a bettor, an opponent, something that is being risked, and an event, as in *Dr. Phil bet Rush Limbaugh a sandwich that Big Brown would win the Kentucky Derby*. As far as we know, there are no 5-, 6-, or 57-argument verbs.

Given that the maximum number of arguments for a verb is four, the problem of storing structural possibilities for verbs is greatly simplified. Instead of having an infinite number of structures associated with each verb, we have between one and five. In the case of *was reading*, everything beyond the subject (*Dr. Phil*) and the direct object (*book*) is optional. The argument structure hypothesis would claim therefore that only two structural possibilities would be stored in long-term memory and associated with *was reading*. When comprehenders access the verb form *was reading*, they would activate two associated syntactic structures, one that did not have a place for a post-verbal object and one that did.

How is this information accessed and used during parsing? According to constraint-based parsing theory in general, and the argument structure hypothesis in particular, when listeners access the lexical representation of a verb like *was reading*, they immediately activate the associated structural information (kind of like what happens with spreading activation in semantic processing). The different structural possibilities are activated to the extent that they have appeared in the past with the verb in question. So if *was reading* most often appeared with a direct and an indirect object, the ditransitive structure will be more active than the intransitive structure. If it appeared most often with just a direct object, then that structure will be more activated than any of the stored alternatives.

The *argument structure hypothesis* provides a somewhat more nuanced view of how argument-hood influences parsing. According to the argument structure hypothesis, argument frames and their corresponding syntactic structures are important because they determine how some elements of sentences are interpreted. For example, how should a comprehender interpret a PP like *to Harry*? It could be interpreted as the

of a transferring action, as in *The bully sent a threatening letter to Harry*, but the PP might be interpreted instead as a location, as in *The bully stapled a threatening letter to Harry* (Boland and Blodgett, 2006, p. 386).

How does a comprehender know which interpretation to apply to the PP? The argument structure hypothesis contends that the subcategory properties of the verb determine how the PP is interpreted. When the lexical representation of the verb specifies a recipient or goal argument (e.g. *sent* specifies a recipient), then a PP headed by *to* will be interpreted as that goal argument. When the verb does not specify a goal argument, prepositional phrases headed by *to* will be interpreted as locations.

Is there any evidence that suggests that the argument structure hypothesis accurately describes how syntactic information is represented in long-term memory? For starters, a growing body of evidence suggests that arguments are treated differently than adjuncts during sentence interpretation. For example, consider sentences (51) and (52) (from Clifton, Speer, and Abney, 1991; see also Stolterfoht et al., 2019):

- (51) The saleswoman tried to interest the man in the wallet. (People interpret this as meaning she wanted him to buy the wallet; not that the man was inside the wallet.)  
 (52) The saleswoman interested the man in his fifties. (People interpret this as meaning that the man was between 50 and 60 years old; not that the saleswoman wanted the man to like being between 50 and 60 years old.)

In sentence (51), *in the wallet* is an argument of the verb *interested* because people have to be interested in something. (Contrast that with the verb *sneezed*. You don't have to sneeze anything, you just have to sneeze.) In (52), *in his fifties* is an adjunct of the noun *man* because, although we can always think or talk about how old the man is, we don't have to. But note that, until we figure out the exact meaning of *wallet* and *in his fifties*, and until we integrate those meanings with the preceding parts of the sentence, it is not clear whether we are dealing with an argument or an adjunct.

According to some accounts of parsing, including the argument structure hypothesis, comprehenders have a general preference or bias to interpret incoming phrases as arguments. Given this assumption, comprehenders will try to treat both *in the wallet* and *in his fifties* as arguments of the verb *interested*. Since *wallet* makes more sense than *his fifties* as something to be interested in, comprehenders should take less time to process *wallet* than *his fifties*. Indeed, when reading times were used to measure processing load, comprehenders were able to process sentences like (51) faster than sentences like (52) (Clifton, Speer, and Abney, 1991; Speer and Clifton, 1998; see also Britt, 1994; Schutze and Gibson, 1999). People thus appear to process argument relations faster than non-argument (or *adjunct*) relations.

Other studies show that people are more satisfied with the outcome of the interpretive process when they can interpret phrases like *to Harry* as arguments as opposed to when they are forced to interpret those same phrases as adjuncts. For example, if people are asked to judge how natural sentences are, they rate sentences where the arguments are explicitly stated higher than sentences where adjuncts, but not arguments, are explicitly stated (Boland and Blodgett, 2006).

Other evidence for an effect of argument status on parsing and interpretation comes from studies showing that people infer a "missing" argument in cases where a verb requires an argument, but the argument is not explicitly included in the sentence (Koenig et al., 2003; Mauner et al., 1995). For example, consider the difference between the simple past tense verb *sank* and the very closely related past perfective *was sunk*. If somebody says *The ship sank*, there does not have to be an external agent. The sentence describes a change of state (the ship goes from floating on the top of the ocean to sitting

on the bottom of the ocean), but the change of state can be internally caused by the ship itself (maybe the hull was very rusty and sprung a leak). However, if somebody says *The ship was sunk*, that means that somebody or something other than the ship was responsible for the change in the ship's state. Do people process sentences like *The ship sank* differently than *The ship was sunk*?

Gail Maurer and her colleagues showed that they do, in the following way: When people hear sentences like *The ship was sunk*, that need an agent but don't explicitly provide one, comprehenders immediately add or infer the presence of the unnamed external agent. So, they interpret the sentence with a missing argument as if it said *The ship was sunk by somebody* .... If the sentence then continues with a *purpose clause*, for example, ... *to collect the insurance money*, that purpose clause is very easy to process, because comprehenders have already inferred that there's somebody involved in the sinking, and that somebody is available to provide the subject of the purpose clause. However, if the sentence starts *The ship sank* ... and continues ... *to collect the insurance money*, then comprehenders have a hard time processing the sentence. Why? Because the beginning of the sentence (*The ship sank* ...) does not require people to infer an agent, so there's nothing in the comprehender's representation of the sentence to connect up with the purpose clause ... *to collect the insurance money*. There's no one in the comprehender's mental representation who could serve as the person with the insurance fraud motive.

## Limitations, Criticisms, and Some Alternative Parsing Theories

Although a considerable amount of experimental work has produced results favorable to a variety of processing accounts that fall within the constraint-based sentence-processing framework, some people still prefer some version of a two-stage parsing theory. There are a number of reasons for this, but let's just focus on two of the main criticisms of the general constraint-based approach.

The first criticism is based on the suggestion that the parser may not always favor likely structures over less likely, but simpler structures (e.g. Clifton et al., 1997). For example, in sentences like (53), the less likely structure is simpler and adopting the less likely structure leads to a semantically odd interpretation:

(53) The athlete realized her shoes somehow got left on the bus.

*The athlete realized her shoes* is just weird. So, if people interpret the beginning of sentence (53) as having a subject, a verb, and a direct object, they should slow down when they read the word *shoes*. But recall that *realized* hates direct objects and really likes sentence complements. If the parser uses this information immediately, then comprehenders should never consider *realized her shoes* as going together inside the same phrase. In that case, comprehenders should have no difficulty with (53), because they will correctly package *her shoes* together with *somehow got left on the bus* to make a sentence complement. When sentences like (53) were used in an eye-movement experiment, readers did slow down at *shoes*, suggesting that they did consider the (incorrect) direct-object interpretation, which would mean that in this case they favored the less likely structure over the likely structure (Pickering et al., 2000).

The second criticism of the constraint-based approach relates to the absence of evidence that sentences with simple syntactic structures are ever hard to process.

return for a moment to the sentence *The burglar blew up the safe with the rusty lock*. According to the constraint-based referential theory of sentence processing, the right kind of story context will cause comprehenders to favor, assign more activation to, or have a bias toward, the more syntactically complex noun-modification interpretation. If that is the case, then when the structurally simple sentence appears in a context that supports the more complex structure, that should make the simple structure harder to process. To date, no such evidence has appeared. Researchers have looked for analogous effects in other sentence types, also without success so far (with one exception, Sedivy (2002), Experiment 4).

Consider, for example, the *main clause* construction in (54) (Binder et al., 2001, p. 312):

(54) The criminal exiled his undependable partner and changed his identity.

Sentences like (54) can be embedded in a story where there are two different criminals. Similar to the *burglar blew up the safe* case, a two-criminal context should encourage comprehenders to favor the complex, reduced relative structure over the simple main clause one as people read the beginning of the sentence (*The criminal exiled ...*). If context changes people's structural preferences in that way (and as predicted by a generic constraint-based account), then sentences like (54) should be harder to process when the story mentions two criminals than when it mentions only one. However, sentences like (54) appear to be relatively easy to process regardless of what information appears in preceding context.

Further criticisms of the constraint-based approach to parsing relate to the testability of various constraint-based proposals and the fact that some types of sentences do not seem to be very susceptible to context effects; interested readers should consult Pickering and van Gompel (2006) for further details, and MacDonald and Seidenberg (2006) for additional arguments in favor of constraints.

More recent theoretical developments in sentence processing have attempted to move beyond the older two-stage and constraint-based processing accounts, while retaining the best features of each approach. Let's briefly consider three of these more recent developments.

## Construal

The *construal* account is essentially a refinement of the classic garden path parsing theory (Frazier and Clifton, 1996). Construal retains the idea that parsing occurs in discrete stages, but it adopts the idea that context can influence which structure the parser prefers and the idea that the parser can sometimes build multiple structures simultaneously. If that sounds a lot like a constraint-based parser to you, pat yourself on the back. But construal differs from the average constraint-based account in that there are a limited set of circumstances under which the parser will respond to contextual information or build syntactic structures in parallel. Most of the time, the construal parser will behave just like the garden path parser. In fact, it will even use the same *late closure* and *minimal attachment* heuristics to make definite decisions about which structural alternative to pursue. How does the parser decide which strategy to use?

To answer that, we need to think about different kinds of relationships between words. Construal says that dependencies between words can come in two flavors, primary and non-primary relations. *Primary relations* correspond roughly to *argument* relations as defined earlier. *Non-primary relations* correspond to everything else. All

other things being equal, the parser prefers to treat incoming material as though it represents a primary relation. When the parser interprets an incoming word or set of words as representing a primary relation, it makes its structural decisions based on the standard garden path processing heuristics. But when the incoming material can't be interpreted as reflecting a primary relation, the parser will use a different strategy to deal with the material. In the first stage, the parser will *affiliate* the incoming material to the preceding sentence context. During this stage, the parser will simultaneously consider all possible attachment sites for the incoming material—effectively building multiple syntactic structures simultaneously. During a following stage of processing, the parser evaluates the different structural possibilities in light of the story context, sentence-level meaning, and other possibly “non-syntactic” sources of information.

To explore the construal parser in greater detail, consider sentences (55) and (56):

- (55) The daughter of the colonel who had a black dress left the party.  
 (56) The daughter of the colonel who had a black mustache left the party.

In (55), people generally interpret the relative clause *who had a black dress* as going with *daughter* rather than *colonel*. In (56), they interpret the relative clause *who had a black mustache* as going with *colonel* rather than with *daughter*. Before you start writing an angry e-mail to my boss (her name is Debra): Of course, it is possible for a colonel to have a black dress. First, colonels can be female. Second, I'll bet you that some male colonels have black dresses in the back of their wardrobe. And yes, it is certainly possible for a colonel's daughter to have a black mustache. Despite these possibilities, most people automatically interpret the sentences in the way just described.

If comprehenders apply the late closure heuristic to parse (55) and (56), they should have an easier time processing (55) than (56). (See if you can work out why this should be the case.) But the construal account says that *who had a black dress* and *who had a mustache* are adjuncts of the preceding noun, and so represent non-primary relations. Under those conditions, the parser *affiliates* the relative clause to the preceding context and simultaneously looks for every place that the relative clause could attach. In (55) and (56), there are two possible hosts for the relative clause (*daughter* and *colonel*). In (55), the *daughter*-related structure works well given the meanings of all of the words involved, and in (56) the *colonel*-related structure works well. So, when it comes time to evaluate the different structural possibilities, there is always one good one. As a result, the construal account predicts no difference in difficulty between (55) and (56), and this is the pattern that actually occurs when participants' reading times are measured (Traxler et al., 1998; for further evidence relating to the construal account, see Frazier and Clifton, 1996.)

## Good-enough parsing

Fernanda Ferreira's *good-enough parsing* hypothesis represents a recent, more radical departure from the classical approaches to parsing and interpretation (Blott et al., 2020; Christianson et al., 2006; Ferreira et al., 2002, 2001; Ferreira and Patson, 2007). Good-enough parsing starts by asking, “What good is parsing, anyway? Do we really need it?” The short answer to these questions is: Sometimes we don't need syntax and parsing at all. For example, if you know someone is communicating about cheese, a mouse, and the act of eating, you can be highly confident that after the event, the cheese is gone and the mouse is heavier, rather than the other way around. In this case, syntax provides con-

that are redundant with the lexical information. The words by themselves tell you everything you need to know, and there is no need to compute syntactic structure to recover the speaker's intentions or the event that inspired the act of communication. In fact, there is some evidence that the lexical level can overpower the syntactic level when the two are placed in opposition. Consider, for example, the *passive* sentence (57):

(57) The mouse was eaten by the cheese.

This sentence sets up a conflict between the lexical–semantic content of the individual words and the sentence meaning that should be derived given standard assumptions about parsing and interpretation. If we transformed sentence (57) into an active form, we would get (58):

(58) The cheese ate the mouse.

But if we rely just on the lexical information, we would get the interpretation expressed by (59):

(59) The mouse ate the cheese.

One very basic question that researchers have addressed is: What meaning do people assign to sentences like (57)? If they build the correct syntactic structure for (57), they should come up with the interpretation in (58). If they just go with the lexical information and don't bother with doing a whole bunch of syntactic parsing, then they will probably come up with the (more sensible, but unlicensed) interpretation in (59). When people are given sentences like (57) and are asked to choose the best paraphrase or suggest an active sentence on their own that expresses the same meaning, many people come up with the sensible, rather than the grammatically licensed, interpretation. This suggests that people may not always compute syntactic relations between words in sentences or that, when the syntax and the lexical level disagree, people prefer to base their interpretation on default lexical–semantic associations. Either outcome would go against standard assumptions about how sentences are interpreted—that people look up words in the mental lexicon, structure the input, and use semantic rules to assign a standard meaning to the structured input.

Further evidence that people fail to construct the correct structure for some sentences comes from sentences like (60):

(60) While the hunter was stalking the deer drank from the puddle.

If participants parse this sentence correctly, they should not interpret the sentence to mean that the hunter was stalking the deer. But when participants were asked directly after reading the sentence “Was the hunter stalking the deer?” they would very likely answer “yes.” That is the result that one would expect if readers left *the deer* attached as the direct object of *was stalking*, but that structure is not licensed by the grammar. You may object that just because, under the correct parse, the sentence does not explicitly say that the hunter was stalking the deer, there is nothing in the sentence that directly contradicts that interpretation. To address that criticism, researchers ran an additional set of experiments using sentences like (61):

(61) While the hunter was stalking the deer in the zoo drank from the puddle.

Because it is very highly unlikely that a hunter would stalk an animal in a zoo, the correct syntactic structure should lead participants to an interpretation where the hunter is stalking something besides a deer. Nevertheless, when participants in this study were asked the same question, “Was the hunter stalking the deer?” they were likely to respond “Yes.” How can that be?

According to the good-enough parsing hypothesis, comprehenders set a threshold for understanding. If the communicative context is high stakes and getting the meaning right is really important, comprehenders will allocate sufficient resources to build syntactic structures licensed by the grammar. Additionally, in those cases where the comprehender initially builds a faulty or incorrect syntactic structure, they will undertake the processes necessary to revise that structure, even if doing so is effortful and resource intensive. However, in most experimental contexts, the stakes are very low (for the participants, anyway), there are no consequences for failing to interpret, and the sentences tend to be tricky and abstract, and refer to little or any real-world content. Under those conditions, participants will do just enough syntactic processing to come up with some meaning. If the syntax is tricky, as it is in sentences like (60) and (61), and participants’ thresholds for feeling like they understand is low, they may not recognize that there is a problem with the syntax—either because they are not actually parsing the input or because they are satisfied with a structure that is not licensed according to the standard grammar.

On top of inability or reluctance to build syntactic structure, comprehenders may be unwilling to abandon an interpretation just because the interpretation is not supported by a licensed parse. For example, it appears that participants in garden path experiments stick with their initial semantic interpretations, while simultaneously showing signs that they are undertaking syntactic revisions at least some of the time. For example, participants persist in thinking that the hunter was hunting deer in sentences like (60) and (61), even though the correct parse, especially of sentence (61), seems to rule out that interpretation. Other experimental evidence also suggests that comprehenders are less likely to successfully revise an initial interpretation when a change in syntactic structure entails a change in meaning (Van Gompel et al., 2006). So, participants appear to maintain initial syntactic commitments when changing a syntactic structure involves changes in semantic interpretation as well.

One problem in distinguishing between the good-enough parsing account and alternative accounts is that we need to have a way to tell the difference between an error and a good-enough parse. If someone reads a sentence and comes up with the wrong meaning, is this because the system is designed to mis-parse the sentence (as assumed under the good-enough parsing account)? Or did they just make an error? In practice, these two possibilities are extremely hard to distinguish experimentally. So, we will need more studies before we can choose whether some version of a determinate parser (like the garden path, constraint-based, and race-based parsers) or a good-enough parser more closely describes the mechanism that people actually carry around in their heads.

## Parsing Long-distance Dependencies

So far, we have been considering the processing of sentences where the words that together to make phrases appear right next to one another as the sentences are produced. For example, in a simple active sentence like (62), the subject, verb, and direct object all adjacent to one another.

(62) The girl chased the boy.

Thus, the relationships between the words in the sentence are classified as *local* dependencies. Many sentences have *long-distance* dependencies (sometimes called *non-local*, sometimes called *unbounded* dependencies), where the words that have close syntactic relationships appear in separate locations in the sentence. Sentence (63) has a meaning very similar to sentence (62), but instead of having all local dependencies, it has some long-distance dependencies.

(63) It was the boy whom the girl chased.

In sentence (63) *the boy* is the object argument of the verb *chased*, but rather than coming right after the verb (which is the normal pattern in English), *the boy* appears before the verb *chased*. As a result, *the boy* and *chased* together form a long-distance dependency. (See if you can think up some other examples of sentences where there are long-distance dependencies.)

Sentences like (62) and (63) are closely related in meaning and, according to some theories of sentence representation and interpretation, they have a common underlying syntactic representation. For example, Noam Chomsky's *gaps-and-traces* account says that people plan and produce sentences like (63) starting with a *canonical* form like the one that you would use to represent the syntax of sentence (62), see (64) (Chomsky, 1965, 1981). *Canonical* syntactic form corresponds to the simplest possible phrase structure that could be used to express the syntactic relationships between the words in a sentence. If we have two actors, a boy and a girl, and an action of chasing, the form in (64) is the simplest structure we could use to express the idea that the girl chased the boy.

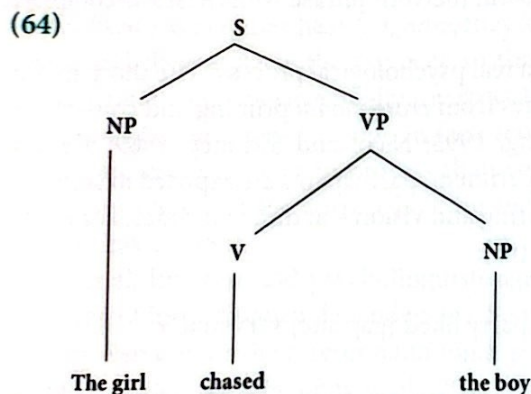

To produce the more complex sentence (63), the gaps-and-traces hypothesis says that people perform *transformations* on the canonical form. These transformations involve moving *the boy* out of its normal direct-object position following the verb *chased* into a position closer to the beginning of the sentence. (Speakers do this when they are trying to draw more attention to the recipient of the action.) Moving *the boy* out of the *chased* VP leaves a void in the syntactic structure of that clause. *Chased* needs a direct object, and because *boy* is no longer there to be the direct object, something has to happen, otherwise the structure would violate the grammar. What happens, according to gaps-and-traces theory, is that people insert a mental placeholder to take the place of the missing direct object. This mental placeholder is called a *gap* or *gap site*. The resulting representation of the *chased* VP looks like the one in (65).

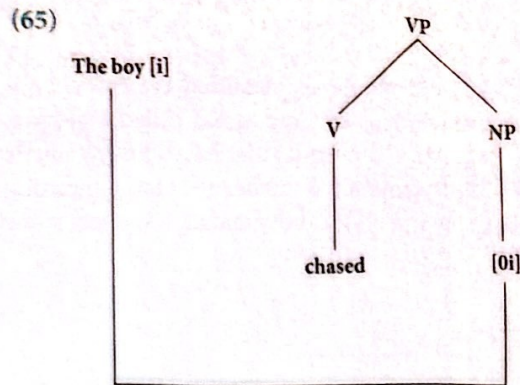

In sentences like (63), the NP *the boy* is called a *filler* or *filler phrase*. According to some linguistic accounts, sentences where all the dependencies are local are parsed by associating words directly with one another. But long-distance dependencies are processed by associating fillers with gaps, rather than by associating fillers directly with the words that govern how they are to be interpreted. So, to parse a sentence like (63), people first identify the filler phrase *the boy*. *The boy* can be recognized as a filler because the phrase *It was ...* oftentimes precedes a displaced element like *the boy* (although sometimes it will be used in a simple declarative statement like *It was lunchtime*). Having identified a filler phrase, people start looking for a place to put it. Right after the verb *chased*, they infer or posit a gap site—because *chased* is missing its direct object. They associate the filler phrase with the gap site and then they associate the gap site with the verb *chased*. Associating the filler phrase and the gap site establishes a “trace” (analogous to a mental pathway) between the filler and the gap site. Doing so allows people to recognize that the *boy* goes together with *chased*, the verb phrase with *chased* is complete, and interpretation can be completed.

Is there any evidence that gap filling is a real psychological process? The short answer is “yes.” Some experimental evidence comes from *cross-modal* priming and *cross-modal naming* experiments (Nicol and Pickering, 1993; Nicol and Swinney, 1989; see also Atkinson et al., 2018). In a *cross-modal* experiment, participants are exposed to language coming in from two different senses—hearing and vision—at different times. For example, people might listen to a sentence like (66):

(66) That's the boy that the people at the party liked [gap site] very much.

In (66), *the boy* is a filler phrase, and the gap site appears right after the verb *liked*. If gap filling is a real psychological process, something special should happen when people reach the gap site. To find out whether something special happens, researchers showed participants target words on a computer screen at different points in time as the participants were listening to sentences like (66). The researchers measured how long it took participants to respond to the visual target words. If the participants responded quickly, that suggests that information associated with the target words was particularly activated or accessible. If people responded more slowly, that suggests that information associated with the target words was less activated. According to the gaps-and-traces account, information about the filler phrase (*the boy*) should be particularly active and accessible right at the gap site. So, if one measured how long it takes people to respond to the filler word itself, people should respond especially quickly right after the verb *liked*. To test that prediction, researchers interrupted the spoken sentence right before the verb *liked*.

(where nothing special should be happening) and right after the verb *liked* (i.e. at the gap site, where something special should be happening), and presented a visual target word. Participants would have to respond to the target word by saying it out loud (“naming” it) as fast as they could. In the experiment, participants responded to target words (like *the boy*) or semantically associated words (like *the girl*) faster after than before the verb *liked*. So it looks like something special did happen right where the gaps-and-traces account says it should.

Sentences like (66) only have one filler phrase and one possible gap site. Other sentences are more ambiguous. For example, sentence (67) has two places where the filler phrase could go (but it actually only goes in one of them, the second one):

(67) That’s the boy that the girl liked [possible gap site] to ignore [actual gap site].

(See if you can think of a sentence that has three possible gap sites.) The possible gap site in (67) is sometimes called a *doubtful gap* because, although it could be the place where the filler goes, the filler does not have to go there (and in this case, it doesn’t). How do people parse sentences with multiple possible gap sites? According to Janet Fodor’s *active filler* strategy, the parser tries to put the filler into every possible gap site as soon as it locates one (Fodor, 1979, 1989). If that were the case, then people would routinely misparse sentences like (67). When they encountered the filler phrase *the boy*, they would start looking for a gap to put it in. There is a possible gap right after *liked*, because the verb *liked* can have a direct object (i.e. the sentence *could* have been the equivalent of *The girl liked the boy*). But if the parser assigns *the boy* as the direct object of *liked*, there will be no room for the actual post-verbal complement of *liked*, the *infinitival* phrase *to ignore*. The active filler strategy therefore predicts that sentences like (67) are a kind of garden path sentence. People first put the filler in the wrong place (in the doubtful gap after *liked*.) When they hear *to ignore*, they know that this filler-gap assignment is incorrect, and they re-parse the sentence so that *the boy* is inside the infinitival phrase *to ignore* (and so people eventually interpret the sentence in the correct way, as meaning *The girl liked to ignore the boy*). In fact, sentences like (67) that have a doubtful gap in them are more difficult to process than equivalent unambiguous sentences when the first gap site is not the correct host for the filler phrase (Pickering and Traxler, 2001, 2003; Stowe, 1986).

Not all linguists and psycholinguists agree that gaps and traces are involved in the parsing of long-distance dependencies. Some theories of grammar do not include gaps as an element of their representational systems—e.g. *Head-Driven Phrase Structure Grammar*, or *HPSG* (see Sag et al., 2003). Some accounts of parsing also do away with the concept of a gap (Pickering and Barry, 1991, 1993). One such account, Martin Pickering and Guy Barry’s *gap-free* parsing account, says that local dependencies and long-distance dependencies are handled in the same way: words are associated directly with one another. So, rather than finding a gap site, when the parser spots a filler phrase, it looks for a word that is missing one of its partners. For example, instead of associating a filler with a gap, and then associating the gap with a verb, the parser associates the filler directly with the verb. How can we decide whether the gaps-and-traces account or the gap-free account does a better job of describing what people actually do when they parse and interpret sentences?

The approach taken by some researchers is to look for sentences where the critical verb comes before the hypothetical gap site. If something special happens at the verb, that would suggest that the filler is associated directly with the verb. If nothing special

happens before people get to the gap site, then that would suggest that the filler is associated with the gap, and *not* directly with the verb. In sentences like (68), the gap site comes well after the verb that goes with the filler:

(68) That's the pistol [filler] with which the killer shot the helpless man [gap] yesterday.

The gap site is after *man* in (68) because, if the sentence were “de-scrambled,” it would say *The killer shot the helpless man with the pistol yesterday*. Does anything special happen at the verb? To find out, researchers compared reading times for sentences like (68) with reading times for sentences like (69):

(69) That's the pistol [filler] in which the killer shot the helpless man [gap] yesterday.

(69) differs from (68) by only a single word (*in* instead of *with*). Changing the preposition from *with* to *in* changes the meaning of the sentence so that (69) makes a lot less sense than (68). In particular, sentence (69) stops making sense at the verb *shot* if people immediately associate the filler phrase *the pistol* with the verb. If people wait until they get to the gap site after *man*, then they will not notice that (69) is odd until well after the verb *shot*. Normally, when a sentence stops making sense, processing load goes up as people try to diagnose what is wrong and correct the problem. So, researchers can use reading time to tell whether processing load has increased. When reading times for (68) are compared to reading times for (69), reading times for (69) are much longer starting at the verb *shot* (Pickering and Traxler, 2001, 2003; Traxler and Pickering, 1996). Since the verb *shot* comes a long time before the hypothetical gap site, it looks like people associate the filler phrase directly with the verb, rather than with a gap. Results like these have motivated some theorists to say that gaps are not necessary, and so they prefer theories that say syntactic structure representations do not include anything like a gap. An additional advantage of the gap-free approach is that we do not need special and different syntactic structure-building processes to handle long-distance dependencies. Both local and long-distance dependencies are parsed by associating words directly with one another.

## Summary and Conclusions

Parsing is an important aspect of interpreting sentences. This chapter has reviewed evidence for and against two- and one-stage theories of human parsing processes. The available evidence suggests that the parser makes use of a wide variety of information very quickly as it is figuring out how words in sentences relate to one another. As a result, many researchers have adopted some version of the constraint-based processing framework to explain how parsing is accomplished. They view syntactic parsing as resulting from the operation of distributed neural networks. Alternative parsing accounts agree with some of the theoretical claims made by constraint-based advocates, such as simultaneous consideration of different syntactic structures, but without agreeing that current neural network models capture all of the key aspects of people's parsing processes. The chapter also described the difference between local and long-distance dependencies and showed that the direct-association hypothesis could explain how both local and long-distance dependencies are parsed and account for experimental results in each domain.

## TEST YOURSELF

1. Describe the relationship between sentence structure and sentence meaning. How does the way that we organize words in sentences influence the meanings we assign to those sentences?
2. What do experiments in which reading times are measured tell us about the process of interpreting a sentence? What do these experiments have to say about incrementality and immediacy?
3. Describe a prominent two-stage account of sentence processing. What experimental evidence supports such an account?
4. What kinds of information can influence the process of building a syntactic structure for a sentence? Give examples of each kind of information.
5. Explain how constraint-based models differ from two-stage models. Describe experiments that support constraint-based models of sentence processing.
6. Describe the argument structure hypothesis. How does it compare to two-stage and constraint-based accounts? Why might a person believe in the argument structure hypothesis?
7. Describe two alternatives to both the two-stage and constraint-based accounts of sentence processing.
8. Describe how long-distance dependencies differ from local dependencies. Describe two accounts of long-distance dependency processing.

## THINK ABOUT IT

1. Draw phrase-structure diagrams for the following sentences. (Hint: (c) may be better represented using a dependency diagram than a phrase-structure tree. Ask your professor for help if you get stuck.)
  - a. Hungry monkeys ate tasty bananas.
  - b. Bananas tasty monkeys hungry ate.
  - c. Tasty bananas ate monkeys hungry.

What do you see when you compare the different kinds of sentences? Which one do you think would be easiest to produce or comprehend? (More hints: (a) is typical in English, (b) is more like Japanese, (c) is like Latin.)

2. Design an experiment to investigate how people respond to syntactically ambiguous sentences. Write some syntactically ambiguous sentences. Write some unambiguous sentences that mean the same thing. Ask your classmates or your friends to provide ratings for the sentences—how much do they like each one, or

how much sense do they make, or how grammatical are they, or how hard are they to understand? Which dependent measures do you think will have different values for the ambiguous sentences compared to the unambiguous ones? Which measurements do you think will be the same for ambiguous and unambiguous sentences? What do you think accounts for these differences (or lack thereof)?

## Note

- 1 Although some theorists contend that phrase structure representations apply universally, they may not be particularly good descriptions for languages that allow words from different phrases to be intermixed. These scrambling languages may be better described in terms of dependencies, rather than phrase structures (Evans and Levinson, 2009).

## References

- Adams, B.C., Clifton, C. Jr., and Mitchell, D.C. (1998). Lexical guidance in sentence processing. *Psychonomic Bulletin & Review*, 5, 265–270.
- Altmann, G.T.M., Garnham, A., and Dennis, Y. (1992). Avoiding the garden path: Eye movements in context. *Journal of Memory and Language*, 31, 685–712.
- Altmann, G.T.M., Garnham, A., and Henstra, J.A. (1994). Effects of syntax in human sentence parsing: Evidence against a structure-based proposal mechanism. *Journal of Experimental Psychology: Learning, Memory, and Cognition*, 20, 209–216.
- Altmann, G.T.M., and Kamide, Y. (2009). Discourse-mediation of the mapping between language and the visual world: Eye movements and mental representation. *Cognition*, 111(1), 55–71.
- Altmann, G.T.M., and Steedman, M. (1988). Interaction with context during human sentence processing. *Cognition*, 30, 191–238.
- Atkinson, E., Wagers, M.W., Lidz, J., et al. (2018). Developing incrementality in filler-gap dependency processing. *Cognition*, 179, 132–149.
- Bates, E., and MacWhinney, B. (1987). Competition, variation, and language learning. In B. MacWhinney (Ed.), *Mechanisms of language Acquisition* (pp. 157–193). Erlbaum.
- Bever, T.G. (1970). The cognitive basis for linguistic structures. In J.R. Hayes (Ed.), *Cognition and the Development of Language* (pp. 279–352). John Wiley & Sons.
- Binder, K.S., Duffy, S.A., and Rayner, K. (2001). The effects of thematic fit and discourse context on syntactic ambiguity resolution. *Journal of Memory and Language*, 44, 297–324.
- Blott, L.M., Rodd, J.M., Ferreira, F., et al. (2021). Recovery from misinterpretations during online sentence processing. *Journal of Experimental Psychology: Learning, Memory, and Cognition*, 47(6), 968.
- Boland, J.E., and Blodgett, A. (2006). Argument status and PP-attachment. *Journal of Psycholinguistic Research*, 35, 385–403.
- Boland, J.E., and Boehm-Jernigan, H. (1998). Lexical constraints and prepositional phrase attachment. *Journal of Memory and Language*, 39, 684–719.
- Britt, M.A. (1994). The interaction of referential ambiguity and argument structure in the parsing of prepositional phrases. *Journal of Memory and Language*, 33, 251–283.
- Brothers, T. (2022). Capacity limits in sentence comprehension: Evidence from dual-task judgements and event-related potentials. *Cognition*, 225, 105153.
- Brothers, T., Hoversten, L.J., and Traxler, M.J. (2021). Bilinguals on the garden-path: Individual differences in syntactic ambiguity resolution. *Bilingualism: Language and Cognition*, 24(4), 612–627.
- Brothers, T., Swaab, T.Y., and Traxler, M.J. (2015). Effects of prediction and contextual support on lexical processing: Prediction takes precedence. *Cognition*, 136, 135–149.
- Brothers, T., and Traxler, M.J. (2016). Anticipating syntax during reading: Evidence from the boundary change paradigm. *Journal of Experimental Psychology: Learning, Memory, and Cognition*, 42(12), 1894.

- Brysbaert, M., and Mitchell, D.C. (1996). Modifier attachment in sentence parsing: Evidence from Dutch. *The Quarterly Journal of Experimental Psychology*, 49A, 664–695.
- Carlson, K., Clifton, C. Jr., and Frazier, L. (2001). Prosodic boundaries in adjunct attachment. *Journal of Memory and Language*, 16, 58–81.
- Carreiras, M., and Clifton, C. Jr. (1993). Relative clause interpretation preferences in Spanish and English. *Language and Speech*, 36, 353–372.
- Carreiras, M., and Clifton, C. Jr. (1999). Another word on parsing relative clauses: Eyetracking evidence from Spanish and English. *Memory & Cognition*, 27, 826–833.
- Chomsky, N. (1965). *Aspects of the Theory of Syntax*. MIT Press.
- Chomsky, N. (1981). *Lectures on Government and Binding*. Foris.
- Christianson, K., Williams, G.C., Zacks, R.T., et al. (2006). Younger and older adults' "good-enough" interpretations of garden-path sentences. *Discourse Processes*, 42, 205–238.
- Clifton, C. Jr., Kennison, S.M., and Albrecht, J.E. (1997). Reading the words *her*, *his*, *him*: Implications for parsing principles based on frequency and on structure. *Journal of Memory and Language*, 36, 276–292.
- Clifton, C. Jr., Speer, S.R., and Abney, S.P. (1991). Parsing arguments: Phrase structure and argument structure as determinants of initial parsing decisions. *Journal of Memory and Language*, 30, 251–271.
- Clifton, C., Traxler, M.J., Williams, R., et al. (2003). The use of thematic role information in parsing: Syntactic processing autonomy revisited. *Journal of Memory and Language*, 49, 317–334.
- Columbia Press. (1980). *Squad Helps Dog Bite Victim*. Doubleday.
- Crain, S., and Steedman, M. (1985). On not being led up the garden path: The use of context by the psychological parser. In D. Dowty, L. Karttunen, and A. Zwicky (Eds.), *Natural Language Parsing: Psychological, Computational, and Theoretical Perspectives*. Cambridge University Press.
- Cuetos, F., and Mitchell, D.C. (1988). Cross-linguistic differences in parsing: Restrictions on the use of the late closure strategy in Spanish. *Cognition*, 30, 73–105.
- Cuetos, F., Mitchell, D.C., and Corley, M.M.B. (1996). Parsing in different languages. In M. Carreiras, J.E. Garcia-Albea, and N. Sebastian-Galles (Eds.), *Language Processing in Spanish* (pp. 145–187). Erlbaum.
- DeLong, K.A., Urbach, T.P., and Kutas, M. (2005). Probabilistic word pre-activation during language comprehension inferred from electrical brain activity. *Nature Neuroscience*, 8(8), 1117–1121.
- Dempsey, J., and Christianson, K. (2022). Referencing context in sentence processing: A failure to replicate the strong interactive mental models hypothesis. *Journal of Memory and Language*, 125, 104335.
- Desmet, T., De Baecke, C., Drieghe, D., et al. (2006). Relative clause attachment in Dutch: On-line comprehension corresponds to corpus frequencies when lexical variables are taken into account. *Language and Cognitive Processes*, 21, 454–485.
- Dussias, P.E., Valdés Kroff, J.R., Beatty-Martínez, A.L., et al. (2019). What language experience tells us about cognition: Variable input and interactional contexts affect bilingual sentence processing. In J.W. Schwieter (Ed.), *The Handbook of the Neuroscience of Multilingualism* (pp. 467–484). John Wiley & Sons.
- Elman, J.L. (1994). Implicit learning in neural networks: The importance of starting small. In C. Umiltà and M. Moscovitch (Eds.), *Attention and Performance: Vol. 15. Conscious and Nonconscious Information Processing* (pp. 861–888). MIT Press.
- Elman, J.L. (2004). An alternative view of the mental lexicon. *Trends in Cognitive Sciences*, 8, 301–306.
- Evans, N., and Levinson, S.C. (2009). The myth of language universals: Language diversity and its importance for cognitive science. *Behavioral and Brain Sciences*, 32, 429–448.
- Ferreira, F., Bailey, K.G.D., and Ferraro, V. (2002). Good-enough representations in language comprehension. *Current Directions in Psychological Science*, 11, 11–15.
- Ferreira, F., Christianson, K., and Hollingworth, A. (2001). Misinterpretations of garden-path sentences: Implications for models of sentence processing and reanalysis. *Journal of Psycholinguistic Research*, 30, 3–20.
- Ferreira, F., and Clifton, C. Jr. (1986). The independence of syntactic processing. *Journal of Memory and Language*, 25, 348–368.

- Ferreira, F., and Patson, N. (2007). The good enough approach to language comprehension. *Language and Linguistics Compass*, 1, 71–83.
- Fodor, J.D. (1979). Parsing strategies and constraints on transformations. *Linguistic Inquiry*, 9, 427–473.
- Fodor, J.D. (1989). Empty categories in sentence processing. *Language and Cognitive Processes*, 4, 155–209.
- Ford, M., Bresnan, J.W., and Kaplan, R.M. (1982). A competence-based theory of syntactic closure. In J.W. Bresnan (Ed.), *The Mental Representation of Grammatical Relations* (pp. 727–796). MIT Press.
- Foss, D.J., and Hakes, D.T. (1982). *Psycholinguistics: An Introduction to the Psychology of Language*. Prentice Hall.
- Frazier, L. (1979). *On Comprehending Sentences: Syntactic Parsing Strategies*. Ph.D. dissertation, University of Connecticut. West Bend, IN: Indiana University Linguistics Club.
- Frazier, L. (1987). Sentence processing: A tutorial review. In M. Coltheart (Ed.), *Attention and Performance 12: The Psychology of Reading* (pp. 559–586). Erlbaum.
- Frazier, L., and Clifton, C. Jr. (1996). *Construal*. MIT Press.
- Frazier, L., and Rayner, K. (1982). Making and correcting errors during sentence comprehension: Eye movements in the analysis of structurally ambiguous sentences. *Cognitive Psychology*, 14, 178–210.
- Fujita, H. (2021). On the parsing of garden-path sentences. *Language, Cognition and Neuroscience*, 36(10), 1234–1245.
- Garnsey, S.M., Pearlmutter, N.J., Myers, E., et al. (1997). The contributions of verb bias and plausibility to the comprehension of temporarily ambiguous sentences. *Journal of Memory and Language*, 37, 58–93.
- Green, M.J., and Mitchell, D.C. (2006). Absence of real evidence against competition during syntactic ambiguity resolution. *Journal of Memory and Language*, 55, 1–17.
- Grodner, D., Gibson, E., and Watson, D. (2005). The influence of contextual contrast on syntactic processing: Evidence for strong-interaction in sentence comprehension. *Cognition*, 95 (3), 275–296.
- Hale, J. (2003). The information conveyed by words in sentences. *Journal of Psycholinguistic Research*, 32(2), 101–123.
- Hale, J. (2006). Uncertainty about the rest of the sentence. *Cognitive Science*, 30(4), 643–672.
- Jackendoff, R. (1990). *Semantic Structures*. MIT Press.
- Jackendoff, R. (2002). *Foundations of Language*. Oxford University Press.
- Just, M.A., and Carpenter, P.A. (1980). A theory of reading: From eye fixations to comprehension. *Psychological Review*, 87, 329–354.
- Kjelgaard, M.M., and Speer, S.R. (1999). Prosodic facilitation and interference in the resolution of temporary syntactic closure ambiguity. *Journal of Memory and Language*, 40, 153–194.
- Koenig, J.P., Mauener, G., and Bienvenue, B. (2003). Arguments for adjuncts. *Cognition*, 89, 67–103.
- Konieczny, L., and Hemforth, B. (2000). Modifier attachment in German: Relative clauses and prepositional phrases. In A. Kennedy, R. Radach, D. Heller, et al. (Eds.), *Reading as a Perceptual Process* (pp. 517–527). Elsevier.
- Kuperberg, G.R. (2021). Tea with milk? A hierarchical generative framework of sequential event comprehension. *Topics in Cognitive Science*, 13(1), 256–298.
- Kutas, M., van Petten, C., and Kluender, R. (2006). Psycholinguistics electrified. In M.J. Traxler and M.A. Gernsbacher (Eds.), *The Handbook of Psycholinguistics* (2nd ed., pp. 659–724). Elsevier.
- MacDonald, M.C., Pearlmutter, N.J., and Seidenberg, M.S. (1994). Lexical nature of syntactic ambiguity resolution. *Psychological Review*, 101, 676–703.
- MacDonald, M.C., and Seidenberg, M. (2006). Constraint satisfaction accounts of lexical ambiguity resolution in syntactic processing. In M.J. Traxler and M.A. Gernsbacher (Eds.), *The Handbook of Psycholinguistics* (2nd ed., pp. 581–612). Elsevier.
- Matchin, W., and Hickok, G. (2020). The cortical organization of syntax. *Cerebral Cortex*, 30(10), 1481–1498.
- Mauener, G., Tanenhaus, M.K., and Carlson, G.N. (1995). Implicit arguments in sentence processing. *Journal of Memory and Language*, 34, 357–382.

- Mitchell, D.C. (1987). Lexical guidance in human parsing: Locus and processing characteristics. In M. Coltheart (Ed.), *Attention and Performance 12: The Psychology of Reading* (pp. 601–618). Erlbaum.
- Mitchell, D.C., Cuetos, F., Corley, M.M.B., et al. (1995). Exposure-based models of human parsing: Evidence for the use of coarse-grained (nonlexical) statistical records. *Journal of Psycholinguistic Research*, 24, 469–488.
- Nicol, J., and Pickering, M.J. (1993). Processing syntactically ambiguous sentences: Evidence from semantic priming. *Journal of Psycholinguistic Research*, 22, 207–237.
- Nicol, J., and Swinney, D. (1989). The role of structure in coreference assignment during sentence comprehension. *Journal of Psycholinguistic Research*, 18, 5–19.
- Nieuwland, M.S., Politzer-Ahles, S., Heyselaar, E., et al. (2018). Large-scale replication study reveals a limit on probabilistic prediction in language comprehension. *ELife*, 7, e33468.
- Phillips, C., Kazanina, N., and Abada, S.H. (2005). ERP effects on the processing of syntactic longdistance dependencies. *Cognitive Brain Research*, 22, 407–428.
- Pickering, M.J., and Barry, G. (1991). Sentence processing without empty categories. *Language and Cognitive Processes*, 6, 229–259.
- Pickering, M.J., and Barry, G. (1993). Dependency categorial grammar and coordination. *Linguistics*, 31, 855–902.
- Pickering, M.J., and Gambi, C. (2018). Predicting while comprehending language: A theory and review. *Psychological Bulletin*, 144(10), 1002.
- Pickering, M.J., and Garrod, S. (2007). Do people use language production to make predictions during comprehension? *Trends in Cognitive Sciences*, 11(3), 105–110.
- Pickering, M.J., and Traxler, M.J. (1998). Plausibility and recovery from garden paths: An eye-tracking study. *Journal of Experimental Psychology: Learning, Memory, and Cognition*, 24, 940–961.
- Pickering, M.J., and Traxler, M.J. (2001). Strategies for processing unbounded dependencies: Lexical information and verb–argument assignment. *Journal of Experimental Psychology: Learning, Memory, and Cognition*, 27, 1401–1410.
- Pickering, M.J., and Traxler, M.J. (2003). Evidence against the use of subcategorisation frequency in the processing of unbounded dependencies. *Language and Cognitive Processes*, 18, 469–503.
- Pickering, M.J., Traxler, M.J., and Crocker, M.W. (2000). Ambiguity resolution in sentence processing: Evidence against frequency-based accounts. *Journal of Memory and Language*, 43, 447–475.
- Pickering, M.J., and van Gompel, R.P.G. (2006). Syntactic Parsing. In M.J. Traxler and M.A. Gernsbacher (Eds.), *The Handbook of Psycholinguistics* (2nd ed., pp. 455–504). Elsevier.
- Pinker, S. (1994). *The Language Instinct*. Harper.
- Rayner, K., Carlson, M., and Frazier, L. (1983). The interaction of syntax and semantics during sentence processing: Eye movements in the analysis of semantically biased sentences. *Journal of Verbal Learning and Verbal Behavior*, 22, 358–374.
- Rohde, D.L.T., and Plaut, D.C. (1999). Language acquisition in the absence of explicit negative evidence: How important is starting small. *Cognition*, 72, 67–109.
- Sag, I.A., Wasow, T., and Bender, E.M. (2003). *Syntactic Theory: A Formal Introduction*. Stanford University Press.
- Schafer, A.J., Speer, S.R., Warren, P., et al. (2000). Intonational disambiguation in sentence production and comprehension. *Journal of Psycholinguistic Research*, 29, 169–182.
- Schutze, C.T., and Gibson, E. (1999). Argumenthood and English prepositional phrase attachment. *Journal of Memory and Language*, 40, 409–431.
- Sedivy, J.C. (2002). Invoking discourse-based contrast sets and resolving syntactic ambiguities. *Journal of Memory and Language*, 46, 341–370.
- Seidenberg, M.S., and MacDonald, M.C. (2018). The impact of language experience on language and reading. *Topics in Language Disorders*, 38(1), 66–83.
- Snedeker, J., and Trueswell, J. (2003). Using prosody to avoid ambiguity: Effects of speaker awareness and referential context. *Journal of Memory and Language*, 48, 103–130.
- Speer, S.R., and Blodgett, A. (2006). Prosody. In M.J. Traxler and M.A. Gernsbacher (Eds.), *The Handbook of Psycholinguistics* (2nd ed., pp. 505–538). Elsevier.
- Speer, S.R., and Clifton, C. Jr. (1998). Plausibility and argument structure in sentence comprehension. *Memory & Cognition*, 26, 965–978.

- Speer, S.R., and Foltz, A. (2015). The implicit prosody of corrective contrast primes appropriately intonated probes (for some readers). In L. Frazier and E. Gibson (Eds.), *Explicit and Implicit Prosody in Sentence Processing* (pp. 263–285). Springer.
- Spivey-Knowlton, M., and Sedivy, J.C. (1995). Resolving attachment ambiguities with multiple constraints. *Cognition*, 55, 227–267.
- St. John, M.F., and McClelland, J.L. (1992). Parallel constraint satisfaction as a comprehension mechanism. In R.G. Reilly and N.E. Sharkey (Eds.), *Connectionist Approaches to Natural Language Processing* (pp. 97–136). Erlbaum.
- Stevenson, S. (1994). Competition and recency in a hybrid network model of syntactic disambiguation. *Journal of Psycholinguistic Research*, 23, 295–322.
- Stolterfoht, B., Gauza, H., and Störzer, M. (2019). Incrementality in Processing Complements and Adjuncts: Construal Revisited. In K. Carlson, C. Clifton Jr., and J.D. Fodor (Eds.), *Grammatical Approaches to Language Processing* (pp. 225–240). Springer.
- Stowe, L.A. (1986). Parsing WH-constructions: Evidence for on-line gap location. *Language and Cognitive Processes*, 1, 227–245.
- Tabor, W., and Hutchins, S. (2004). Evidence for self-organized sentence processing: Digging-in effects. *Journal of Experimental Psychology: Learning, Memory, and Cognition*, 30, 431–450.
- Tanenhaus, M.K., Spivey-Knowlton, M.J., Eberhard, K.M., et al. (1995). Integration of visual and linguistic information in spoken language comprehension. *Science*, 268, 1632–1634.
- Traxler, M.J. (2002). Plausibility and subcategorization preference in children's processing of temporarily ambiguous sentences: Evidence from self-paced reading. *Quarterly Journal of Experimental Psychology*, 55A, 75–96.
- Traxler, M.J. (2005). Plausibility and verb subcategorization preference in temporarily ambiguous sentences. *Journal of Psycholinguistic Research*, 34, 1–30.
- Traxler, M.J., and Frazier, L. (2008). The role of pragmatic principles in resolving attachment ambiguities: Evidence from eye-movements. *Memory & Cognition*, 36, 314–328.
- Traxler, M.J., and Pickering, M.J. (1996). Plausibility and the processing of unbounded dependencies: An eye-tracking study. *Journal of Memory and Language*, 35, 454–475.
- Traxler, M.J., Pickering, M.J., and Clifton, C. Jr. (1998). Adjunct attachment is not a form of lexical ambiguity resolution. *Journal of Memory and Language*, 39, 558–592.
- Traxler, M.J., and Tooley, K.M. (2007). Lexical mediation and context effects in parsing. *Brain Research*, 1146, 59–74.
- Trueswell, J., Tanenhaus, M. K., and Kello, C. (1993). Verb-specific constraints in sentence processing: Separating effects of lexical preference from garden-paths. *Journal of Experimental Psychology: Learning, Memory, and Cognition*, 19, 528–553.
- Trueswell, J.C., Tanenhaus, M.K., and Garnsey, S.M. (1994). Semantic influences on parsing: Use of thematic role information in syntactic ambiguity resolution. *Journal of Memory and Language*, 33, 285–318.
- Tutunjian, D., and Boland, J.E. (2008). Do we need a distinction between arguments and adjuncts? Evidence from psycholinguistic studies of comprehension. *Language and Linguistics Compass*, 1, 631–646.
- Van Gompel, R.P.G., and Pickering, M. (2001). Lexical guidance in sentence processing: A note on Adams, Clifton, and Mitchell. *Psychonomic Bulletin & Review*, 8, 851–857.
- Van Gompel, R.P.G., Pickering, M.J., Pearson, J., et al. (2005). Evidence against competition during syntactic ambiguity resolution. *Journal of Memory and Language*, 52, 284–307.
- Van Gompel, R.P.G., Pickering, M.J., Pearson, J., et al. (2006). The activation of inappropriate analyses in garden-path sentences: Evidence from structural priming. *Journal of Memory and Language*, 55, 335–362.
- Van Gompel, R.P.G., Pickering, M.J., and Traxler, M.J. (2000). Unrestricted race: A new model of syntactic ambiguity resolution. In A. Kennedy (Ed.), *Reading as a Perceptual Process* (pp. 621–648). Elsevier.
- Van Gompel, R.P.G., Pickering, M.J., and Traxler, M.J. (2001). Reanalysis in sentence processing: Evidence against current constraint-based and two-stage models. *Journal of Memory and Language*, 45, 225–258.
- Wang, L., Schoot, L., Brothers, T., et al. (2021). Predictive coding across the left fronto-temporal hierarchy during language comprehension. *Cerebral Cortex*, doi: 10.1093/cercor/bhac356.